

Your Care After Leg Amputation Below Knee



Table of Contents

About Your Care and Rehabilitation

About Your Care	4
What to Expect	5

Daily Care and Preventing Problems

Understanding Vascular Disease	6
Preventing Problems from Vascular Disease	8
Daily Foot Care and Safety	9
Making the Most of Your Healthcare Visits	13
Skin Care and Sensitivity	15
Wound Care	16

Care of Your Residual Limb

Wrapping for Below Knee Amputation	18
Shrinker Sock Use to Reduce Swelling	20
Removable Rigid Dressing	21
Preparing for Prosthesis	24

Pain Management

About Pain and Pain Control	26
Phantom Pain	28
Mirror Therapy	30

Talk to your doctor or healthcare team if you have any questions about your care.

For more health information, go to wexnermedical.osu.edu/patiented or contact the Library for Health Information at 614-293-3707 or health-info@osu.edu.

Positions, Stretches, and Strengthening

Positioning and Stretches	31
Strengthening Exercises	34

Healthy Living

Heart Healthy Eating with DASH	40
Leisure as Part of Your Rehabilitation	44
Adapted Sports and Recreation	46
Saving Energy and Making Work Easier	49

Mental Health

Phases of Recovery from Amputation	50
Depression after Amputation	51
Adapting to Life	53
Relaxation Techniques	54

Mobility

Using Walker on Curbs Without Prosthesis	55
Using Crutches With Amputation	56
Taking a Wheelchair Up and Down Stairs and Curbs	59
How to Adapt an Entrance for a Wheelchair	61

Prosthesis

Overview of Peer Support	64
Resources and Support Groups	66
Prosthetic and Orthotic Companies	67

For a digital copy of this book, please visit go.osu.edu/pted4148.

About Your Care

Amputee rehabilitation

Amputee Rehabilitation at Ohio State Wexner Medical Center supports the physical and emotional needs you will have after the loss of limb, whether due to an accident, illness, birth defect, or cancer. We will help you gain new skills and learn to adapt as you become more independent.

Our services

The Specialty Amputee Program offers rehabilitation services to help in each phase of your recovery — from services provided in the hospital (inpatient services) to those offered after returning home (outpatient services). They are all designed to help you reach your highest level of recovery.

We can help you:

- Care for your amputation to prevent future problems
- Have comfort and independence with your amputation if you do not have an artificial limb
- Prepare for an artificial limb (prosthesis) for the best fit and function
- Return to driving, if possible
- Return to work and daily activities, such as walking and climbing stairs, if possible

Your treatment team

After your surgery, our team of doctors, nurses, and therapists is specially trained for after-amputation care. Your team of specialists may include:

- **Doctors** who specialize in diagnosing and treating patients with injuries or diseases.
- **Nurses** who specialize in patient care, health promotion, and disease prevention.
- **Physical therapists** who specialize in helping patients with strength, balance, and mobility.
- **Recreational therapists** who specialize in adapted recreation, adjusting to disability, and returning to the community
- **Occupational therapists** who specialize in improving patients' ability to do daily life activities.
- **Prosthetists** who specialize in fitting, adjusting, and caring for artificial limbs.
- **Pain management specialists** who specialize in evaluating and treating patients' pain.
- **Dietitians** who specialize in nutrition and diet changes to support your health and wellness.
- **Counselors** who provide a variety of counseling, rehabilitation, and support services.

About this book

This book will be used to teach you about your care. You are not expected to learn all of this information before you go home, but keep this book to use as a resource. If you do not understand something, let your healthcare team know and they will explain another way.

What to Expect

You may receive care from Ohio State Wexner Medical Center from surgery through recovery, or just for rehabilitation and therapy. Whatever your journey, we would like to give you an idea of what you can expect.

After surgery

While in the hospital after your surgery, your healthcare team will teach you how to take care of your incision and residual limb. They will teach you how to check your skin and watch for problems. You will also begin learning to safely move around.

Inpatient rehabilitation at Dodd Rehabilitation Hospital

The goal of rehabilitation is to return you to the highest quality of life at home, at work, and in the community. We offer many types of therapy to help you with your recovery. The therapy is tailored to you, so you will be involved in planning your treatment.

Your therapy goals may include helping you to move around safely, adjusting to doing daily activities in a new way, using new equipment, or doing leisure activities. You will later practice the skills learned in therapy in your room with the help of your rehab team.

Our team will do all we can to support you, your family, and your caregivers as you recover.

Outpatient rehabilitation

With Outpatient Rehabilitation Services at Ohio State's Wexner Medical Center, we know each patient is an individual, with individual needs and goals. That is why your therapy program will be personalized to you. Your team will work with you to develop your care plan. Family and caregivers are encouraged to take part, and help set goals.

Your therapy goals may include:

- Working on activities that you are having problems with in your daily life
- Planning for your long-term needs
- Setting goals for living at home, self-care, and staying safe in the community
- Exercise and training programs
- Recommending equipment and changes to your home
- Helping you continue to adapt and gain new skills

The time you spend in the clinic is designed to challenge you and give you things to work on at home and in the community.

Understanding Vascular Disease

What is vascular disease?

Vascular disease is a condition where there is a problem with blood flow and circulation in the body. The vascular system, also called the circulatory system, is made up of vessels that carry blood and lymph throughout the body. Normal blood flow transports blood to and from areas of the body without interruption. Lymph gets rid of waste products in your cells, helping the body to fight infection.

With vascular disease, there may be problems in veins, arteries, or lymph:

- **Arteries:** Carry blood full of oxygen and nutrients from the heart and lungs to all other areas of the body.
- **Veins:** Return the blood that has waste products from all parts of the body back to the heart and lungs.
- **Lymph vessels and nodes:** Vessels that carry lymph to all parts of the body. Nodes are small glands that can be felt in the armpit, groin, neck, under the jaw and chin, and behind the ears.

Your risk for vascular disease

Many people are at risk for vascular disease, depending on their health, lifestyle behaviors, and family history. Common risk factors include:

- Being age 45 years or older
- A self or family history of coronary artery disease (CAD)
- A family history of vascular disease
- A sedentary lifestyle and/or poor diet
- Tobacco use
- Having high cholesterol or lipids
- Having high blood pressure
- Having diabetes
- Being overweight

Types of vascular disease

The disease may be called other names, based on the body system affected:

- **Atherosclerosis or hardening of arteries:** Plaque builds up on the lining of arteries limiting blood flow. As the blood vessel narrows, it is harder for oxygen-rich blood to flow.
- **Peripheral artery, peripheral vein, or renal artery disease:** The peripheral arteries and veins are those blood vessels that are located outside of your heart. You may hear the terms PAD or PVD to describe where arteries or veins are blocked with plaque. If the artery to the kidney is blocked, it is called renal artery disease.



Normal artery

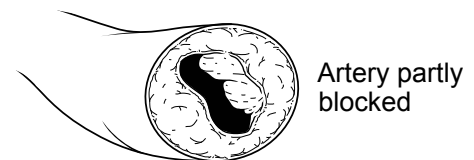

Artery partly blocked



Artery totally blocked with blood clot

- **Carotid Artery Disease:** Arteries on either side of the neck are blocked from plaque, or there may be a blood clot.
- **Blood Clots:** Blood clots can occur when there is prolonged bed rest or lack of movement, damage to veins from injury, infection, or other conditions that cause slow blood flow.
 - **Deep vein thrombosis (DVT)** is a serious condition where the clot is in a deep vein of the chest, pelvis, or leg.
- **Aneurysm:** A weak part of a blood vessel wall that swells and bulges out, limiting blood flow. Aneurysm is more likely to occur in the aorta (heart), abdomen, or kidneys.

Other vascular problems

- **Lymphedema:** Swelling in the body from problems with draining lymph.
- **Varicose and spider veins:** A vein will swell when the valves inside the vein do not work well to regulate blood flow. Varicose veins are enlarged and can appear twisted or bulging. Spider veins are like varicose veins, but smaller and closer to the surface.
- **Buerger's disease:** Leads to blocked veins in the arms and legs causing low blood supply to the hands and fingers or feet and toes.
- **Raynaud's disease:** Skin of the hands or feet may be white or bluish and feel numb or cold. This usually occurs when it is cold out.

Signs

In the early stages, you may not have any signs of vascular disease. If you are not being treated for it, you may have the following signs of poor circulation over time:

- Pain, called claudication, in your leg or foot, that happens while walking or during exercise. While pain may stop at rest, some people report muscle spasms and pain in advanced vascular disease.
- Feel dizzy, faint, or have a headache.
- Feel numb or lose muscle control where circulation is poor. It is more common in the arms, legs, muscles of the face, or one side of the body.
- Cool, pale skin, or cold hands and feet.
- Skin color under nails of fingers and toes may be reddish-blue, especially when legs are down or lower than the heart.
- Trouble speaking.
- Sores or wounds that take a long time to heal or look dark (black) in color.
- Loss of hair on legs and feet.
- Weak pulse in the legs and/or feet.

Testing and treatment

If you have one or more of these signs, see your healthcare provider. Tests may be done to find out the cause of your problem and options for treatment. Treatment types for vascular disease include lifestyle changes, medicines, and surgery.

Preventing Problems from Vascular Disease

If you have had an amputation because of vascular disease, you can reduce your risk of problems by taking steps to prevent the build up of plaque in your arteries. Some key steps include staying active, not smoking, managing diabetes, and proper foot care.

Stay active and keep blood circulating

- Do some form of physical activity each day. Your therapist will work with you to find exercises that are right for your ability level.
- Do not stay in the same position for long periods of time. Try to vary your activity throughout the day.
- Learn the proper positions for sitting and lying down.
- Do not wear tight clothing on your lower body.



Don't smoke or use nicotine in any form

- Tobacco in any form causes serious damage to the arteries, causing them to constrict.
- Nicotine found in tobacco makes it harder for the blood to carry oxygen and to travel through the blood vessels. Nicotine can be found in products like cigarettes, e-cigarettes (vapor), and smokeless tobacco.
- There are many smoking cessation programs available to help you quit. Ask your healthcare provider about options.



Manage your diabetes

- If you have diabetes, it is very important to keep your blood sugar (glucose) within the recommended levels.
- Blood sugar control will help decrease long-term complications, such as decreased blood circulation, ulcers on your foot or leg, kidney failure, or vision problems.



Foot care

- Take good care of your foot. Have a plan for daily care and first aid, choose good footwear, and have your doctor check your foot at each visit. Learn more about this starting on the next page.



Daily Foot Care and Safety

After a leg amputation, taking care of your foot is very important. If your amputation is because of vascular disease or diabetes, you are at even higher risk for problems.

To take care of your foot, have a plan for daily care and first aid, choose good footwear, and have your doctor check your foot at each visit.

Daily care

Every day:

1. **Look at your foot** and pay special attention to the:

- Top and bottom
- Sides and heel
- Toes and toenails
- Between each toe

You may need to use a mirror or a magnifier to help you see all the parts of your foot and toes.

Watch for these changes:

- Redness
- Infection
- Sores
- Ingrown toenails
- Dryness
- Cracks in the skin
- Blisters

If you notice any of these changes, contact your doctor.

If you cannot reach or see your foot, ask a family member, friend, or nurse to check your foot for you.

2. Wash all parts of your foot with a mild superfatted soap, such as Dove or Basis, a clean wash cloth, and warm water. Be sure to rinse off all of the soap because it can build up and dry out your skin.

3. Dry your foot well using a clean towel. Gently pat dry all areas of the foot and carefully **dry between each toe.**

4. Apply lotion on your foot. Choose a lotion that has lanolin and is alcohol-free. Do not put lotion between your toes. If sweating is a problem, lightly sprinkle cornstarch or talcum powder on your foot after drying it.



Nail care

Trimming your toenails can be hard to do if they are thick or brittle. If you have poor vision or cannot reach your foot, it may also be hard to trim your own nails. A family member or foot doctor (podiatrist) will need to help you with your toenail care if you have problems doing it.

If you are able to trim your own nails, follow these guidelines:

- File your toenails straight across and to the shape of your toe. Use an emery board, a type of nail file that uses a rough surface to file nails.
- Avoid filing your toenails too short as this can lead to ingrown nails.
- If your toenails are thick and hard, cut the nails after a bath or shower, when the nails are softer.
- Use good light when trimming or filing your nails.
- Be careful to cut just your toenails, not your toes or foot.
- Never use sharp or pointed objects to cut your toenails. Even a metal file can be dangerous.

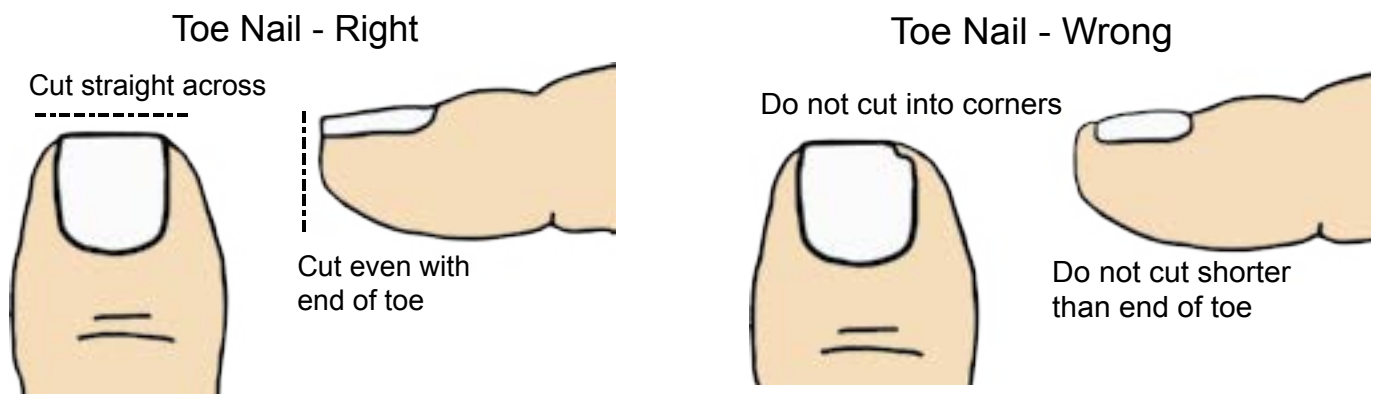

Foot first aid

Finding and treating a foot sore or injury early is important for preventing more serious problems.

If you injure your foot or notice a sore, follow these steps:

1. Clean the area with mild soap and warm water.
2. Pat the area dry with a clean towel.
3. **Do not** use antibiotic ointments, such as Neosporin or Bacitracin, unless your doctor tells you.
4. Cover the area with a plain gauze pad.
5. Wrap gauze around your foot and secure the gauze with tape. **Do not** put tape on your skin.
6. Stay off of your foot.

Contact your doctor if:

- You have signs of infection, such as redness, foul smell, or pus.
- Your sore or injury is not better after 24 hours.

Protect your foot

Feet are prone to injury, so it is important to do things to protect them.

- **Do not** go barefoot indoors or outdoors.
- **Do not** use heating pads, space heaters, or hot water bottles on or near your foot.
- **Do not** use harsh chemicals, such as iodine, corn removers, betadine, alcohol, or peroxide. These can burn your skin.
- See your podiatrist regularly.
- Gently file calluses with a pumice stone, file, or emery board.
- Carefully file your toenails straight across using an emery board.
- **Do not** wear tight clothes, such as girdles, garters, or slacks. These can decrease circulation to your foot.
- **Never** soak your foot. This dries out the skin.
- **Do not** cut your calluses or corns.
- **Do not** expose your foot to very hot or cold temperatures.

Choose good footwear

Socks

- Wear socks that are made of 70% to 90% natural fibers, such as cotton, silk, or wool. They allow your foot to breathe. Synthetic fibers trap moisture against your foot.
- Wear white socks, so you can easily see drainage or blood.
- Wear a clean sock every day.
- Do not wear socks that have been darned (patching that usually creates a thicker area), have holes, or have thick seams. These areas can cause pressure and could lead to a foot sore.
- Do not wear tight socks or hose.
- Wear socks that match the shape of your foot.
- Always wear a sock with your shoe.



Shoes

Every day:

- Check the inside of your shoe for stones and other objects before putting it on.
- Check your foot after taking off your shoe for red areas. Red areas could mean the shoe is too tight.
- If possible, rotate your shoes and do not wear the same shoe every day.
- Change your shoe and sock if you are on your foot a lot during the day.



- If you are not sure if your shoes fit properly, bring them in for your doctor or nurse to check.
- Never wear a new shoe for more than 1 to 2 hours in a day until it is “broken in.”

When buying new shoes:

- Always have your foot measured.
- Choose shoes that tie on the top.
- Check the toe area to be sure it is wide enough.
- Choose soft leather or canvas, which lets your foot breathe.
- Choose a shoe that matches the shape of your foot.
- Choose a rubber sole. This helps absorb the shock or pressure of the hard ground.
- Choose a low heel that is 1 inch high or less.
- Ask about shoe brands that may best to meet your needs. If you have foot problems, such as hammer toes or bunions, you may need special shoes. Tell the sales person if you have decreased feeling or numbness in your foot.

Doctor appointments

Work with your healthcare team to take care of your foot and prevent problems. At visits, you can expect your doctor or nurse to:

- Check your foot and see that your shoe fits properly.
- Check for both nerve damage and poor circulation.
- Recommend you see a podiatrist or have special tests if needed.
- Recommend a special shoe if you need it.

Use your doctor’s appointment to learn more about your foot. You should:

- Always take your shoe and sock off at each visit.
- Discuss any foot problems you have had since your last appointment.
- Ask questions about what you can do to protect your foot.

Making the Most of Your Healthcare Visits

It is a good idea to organize your information and write down any questions you have before you see your healthcare provider. Here are some tips that will help you make the most of your visit.

Organize your health information

Keep a notebook of your health history to help you remember dates, health problems, or treatments you have had. This makes it easier to share your health history with your healthcare provider. Below are suggestions of things that you may want to keep notes on. Do not worry if you do not have all of this information.

Record dates and notes about:

- Past and present health problems, including mental health
- Type of birth control you or your partner use
- Surgeries or procedures you have had
- Medical tests and results
- Vaccines you have had
- Allergies you have and your reactions
- Past pregnancies and date of last menstrual cycle, if it applies
- Family medical history, including cancer (type and age it started)
- Any medical devices you use, such as a walker, nebulizer, or CPAP machine

You may also want to keep a list of your:

- Doctors and other providers, with phone numbers and addresses
- Pharmacy phone number and location, including mail order pharmacies

Things to bring

- Insurance information
- Photo ID, such as your driver's license
- Your list of questions
- Your list of medicines
- Glasses or hearing aids, if needed

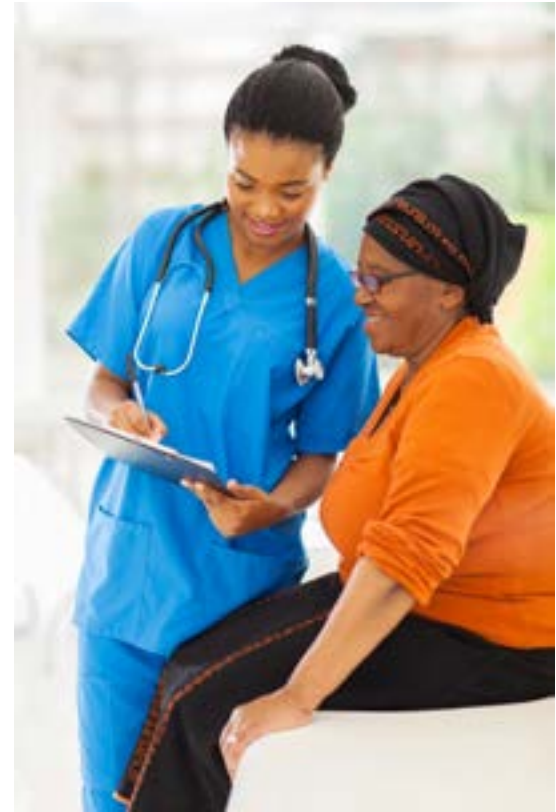

Medicine list

Keep a list of all of the medicines you take in your wallet. Include prescriptions, over the counter medicines, and any vitamin or herbal products you take. Include eye drops, inhalers, and creams.

Your list should include:

- Name of the medicine
- Why you take it
- How much you take
- When you take it

Preparing for your visit

- Write down any questions you have. Underline the ones that you want to make sure are answered.
- Write down any symptoms or problems, especially any new symptoms you have had since your last visit.
- Ask a friend or family member to come with you to listen and take notes while you are talking with your provider.
- For patients who do not read, speak, or understand spoken English, arrangements can be made for someone who speaks their language, called an interpreter, to help at the visit. An interpreter may come in person to the appointment or use a telephone or video screen. Tell the office or clinic (before the appointment if possible) if an interpreter is needed.

During your visit

- Ask about anything you don't understand.
- Make sure you understand any medicine you need to take, including how much you should take, the time of day you should take it, and for how many days. Ask about any side effects you should watch for and what you should do if these happen to you.
- Ask for written instructions or make your own notes about your care.
- It is helpful if you can schedule your next appointment at the end of each office or clinic visit. Be sure to mark your appointments on a calendar as a reminder.

Skin Care and Sensitivity

Skin checks

You need to check the skin on your residual limb to look for signs of inflammation, irritation, or pressure.

Things to look for:

- Redness or warmth of the skin
- Drainage from the suture line
- Blisters or open sores
- Tenderness or swelling
- Dry or cracked skin

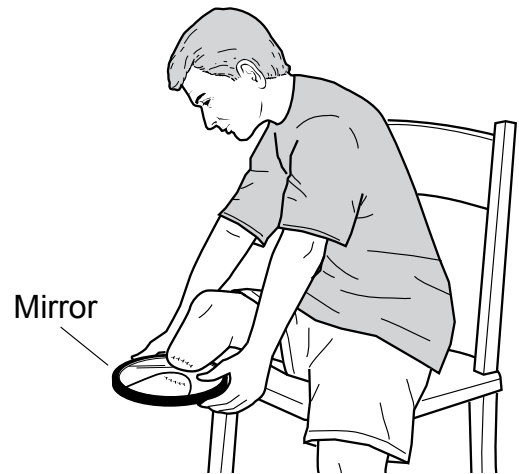

How to do the check:

Check your skin at least every other day to find problems early. Early treatment can help prevent problems from becoming more serious.

- Check all around your residual limb. Use a mirror to look at the back and end of your residual limb, any bony spots, and skin creases.
- If you are wearing a wound dressing with shrinker sock or rigid dressing, you should check your skin at the amputation site each time you change the dressing.
- If you find a red spot, blister, open area, or other skin problem, call your doctor or a member of your rehab team right away.

Becoming less sensitive to touch and pressure

It is important to work on making your residual limb less sensitive to touch and pressure. This helps prepare you for a prosthesis. Some people also find it helps with phantom pain.

- **Limb massage and tapping:** Early massage and tapping of your residual limb will help you develop a tolerance to both touch and pressure.
- **Desensitization:** This is the process of making your residual limb less sensitive to touch. You begin with a soft material and progress to rougher materials.
- **Scar massage:** Massaging the area around your scar helps keep the scar loose and less thick. If the scar attaches to the tissue, it can cause more pain and be a site for blisters if you wear a prosthesis.

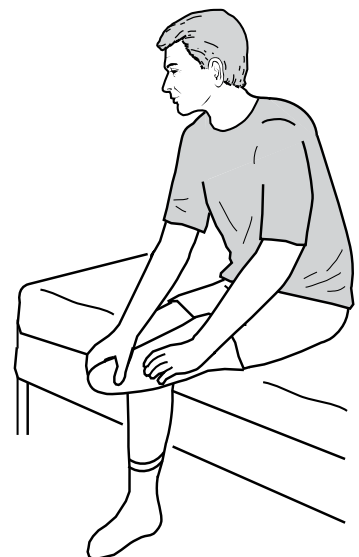

Wound Care

Wound care is done to clean your wound or incision, inspect the area, and to prevent infection.

- Do your wound care as often as directed by your doctor or if the dressing is wet, gets dirty, or becomes loose.
- You can stop doing this care when the drainage stops.
- If you remove the dressing and there is no drainage on the gauze, you can leave the dressing off.

Getting ready

1. Wash your hands with warm water and soap.
2. Clean the work area by washing the area with soap. Rinse and dry the area with a clean paper towel.
3. Gather the supplies and place them on the clean work area:
 - Gauze pads or clean wash cloths to clean and dry wound
 - Adaptic (petroleum ointment) dressing
 - 4 x 4 gauze pad or 5 x 9 ABD (abdominal) dressing pad
 - Gauze wraps or Kling roll
 - Plastic bag for old dressing
 - Soap and water or saline to clean wound
 - Clean towel
 - Other _____



Removing the old dressing

1. Remove the Ace wraps from your residual limb and set it aside.
2. Put a towel under your leg before you take the old dressing off.
3. Gently remove the dressing from the wound. If the dressing is stuck, wet the dressing with tap water, wait 15 to 30 seconds, and then remove it. You can wet it and wait longer if you still cannot remove the dressing.
4. Place the old dressing in the plastic bag.

Cleaning the wound

1. Wash your hands again.
2. Use soap and water on a gauze pad or clean cloth. Start at one end of the wound and clean to the other end. Be sure to wash away any drainage or dried blood.
3. Wash over the incision, but do not scrub it hard.
4. Pat gently with a dry gauze pad or clean towel, drying from one end to the other.
5. Inspect the wound for redness, drainage, swelling, or odor.
6. Cover the wound with a new dressing. First put on the Adaptic (petroleum ointment) dressing if you have drainage. Then follow with a gauze pad or ABD pad. Wrap with the gauze roll or Kling to hold the dressing in place. Your treatment team will tell you when to stop doing this step.
7. Apply the Ace wraps around your residual limb.
8. Clean up the work area and place the old dressing in the trash.
9. Wash your hands again.

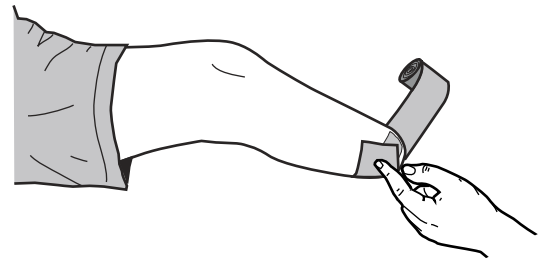
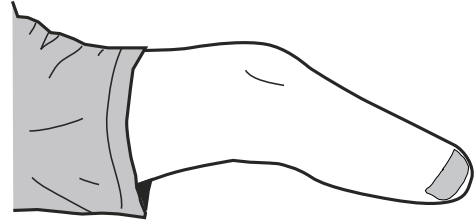
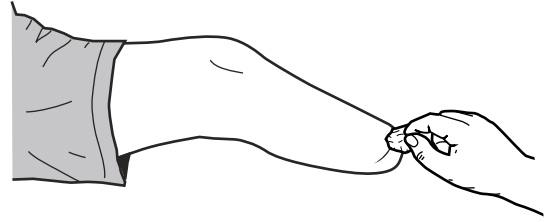

Call your doctor if you have:

- Increased pain in or around the wound
- Change in the amount of drainage
- Change in color or odor of drainage
- A wound that gets larger
- Red streaks on the skin near the wound
- Redness or increased warmth in the area around the wound

Wrapping for Below Knee Amputation

Using Ace wraps

- Use 4 or 6 inch Ace wraps.
- Re-wrap your residual limb with an Ace wrap as directed by your doctor.
- Wash the Ace wrap every 2 to 4 days. Dry flat and make sure there are no wrinkles.
- Make sure all areas are covered.
- Hold the wrap to keep tension on it as you wrap it.
- The wrap should be snug, but you should be able to easily slide a couple of your fingers under the wrap.



How to wrap for below the knee

1. Start above the knee to anchor the wrap around your leg. Make a circle with the wrap around your leg.
2. Take the wrap to the back of the leg and then across and down your residual limb. This starts the figure 8 pattern.
3. Bring the wrap around to the front of your limb, and then across and up towards the knee.
4. Wrap around the back of the knee and then down across your limb.
5. Wrap around the base of your limb and then up and across towards the knee. Put more pressure at the bottom of your limb with the wrap than at the top, so you do not slow blood flow to your limb.
6. Continue to repeat steps 4 and 5 until your limb is covered. The edges of the wrap should overlap.
7. Secure the end of the wrap to hold it in place. You can use tape or Velcro. Avoid using safety pins or clips to reduce injury to the skin.

Ace wrapping steps

Step 1

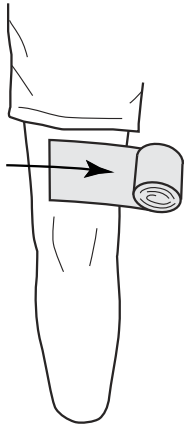

Step 2

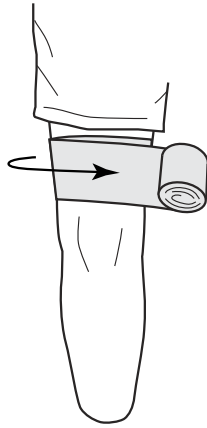

Step 3



Step 4

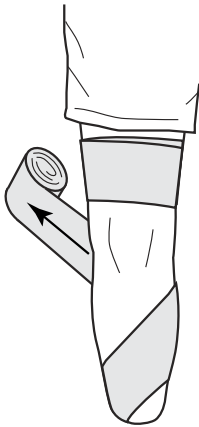

Step 5

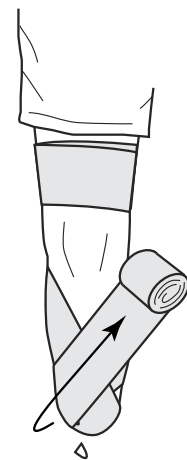
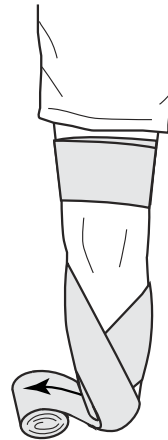

Step 6

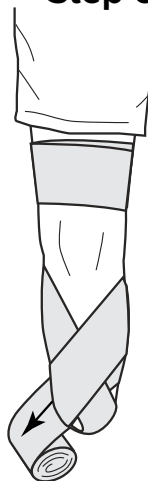

Step 7

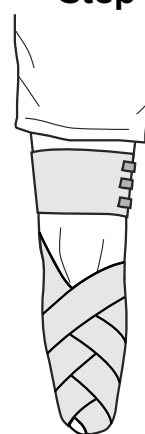

Shrinker Sock Use to Reduce Swelling

Use of shrinker socks

- An elastic shrinker sock may be used to help control swelling in your residual limb.
- It may be best to stretch the sock before placing it on your residual limb if it is still very sensitive to touch and pressure.
- The sock should be pulled tight against the end of your limb, with no gap between the end of your limb and the sock.

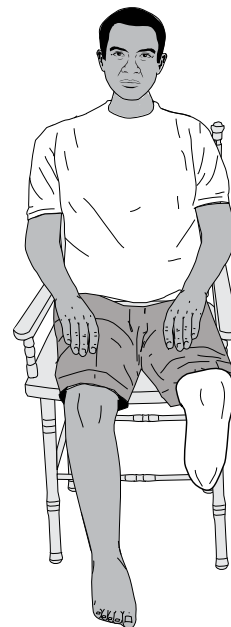

Stretching the sock

Use the application can if one was provided to you (see instructions for that on the next page, steps 2 and 3). If one was not provided, use these instructions below.

Steps:

- Hold onto the top of the sock with both hands. Your fingers should be on the inside of the sock and your thumbs on the outside.
- Gather or scrunch the extra material down in your hands and pull to stretch out the sock until the bottom is flat.
- Place the flat inside part of the sock against the end of your residual limb.
- Keeping the stretch on the sock, pull the sock up the leg in one motion. The material will slide from between your thumbs and fingers.

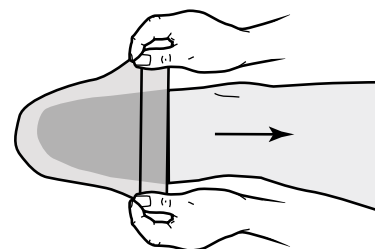
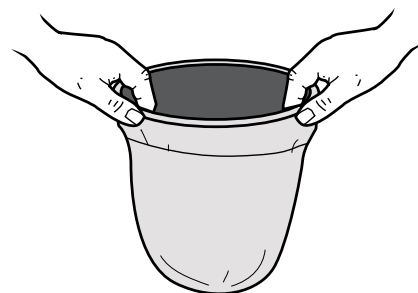

Additional education may be available through the maker of your equipment.

Removable Rigid Dressing

The rigid dressing that has been made for you is removable, called a removable rigid dressing or RRD.

Your therapist will teach you how to put on and remove the dressing. Here are the basic steps.

How to apply the removable dressing



1. If your incision is draining, place a dry dressing over it, according to your doctor's orders.



2. Slip the closed end of the first sock into the can. Open it inside the can and stretch it around the can opening. Do not let the sock curl over the can end. Make sure the sock is flat before applying to your limb.



3. Holding on to the sock and can, place your limb in the center of the can. Gently roll the sock up the can and then up your limb.



4. Apply the second compression sock to the can.



5. This sock does not have a closed end and goes completely over the can.

6. Place the can back on your leg and pull the sock onto your leg, lining up your kneecap with the marked kneecap space on the sock.



7. Pull the can down until it is just past the end of your leg.

8. Look inside the can and twist the can just until you can no longer see the first sock. Then push the rest of the sock onto your leg.



9. Slide hard dressing onto the end of the leg, rocking in a back-and-forth motion. If the hard dressing is too loose, add more single ply socks. Put on with seams facing out and not lined up on top of each other.

10. Stretch the remaining compression sock from the hard dressing up over the rest of the leg, lining up with the marked kneecap.

Change your dressings according to your doctor's orders.

Care at home

- Remove the dressing each day to check the incision. Do not leave the dressing off for more than 15 minutes. This will give your leg a chance to swell, and you will not be able to get the dressing back on.
- If the dressing becomes too loose, add 1-ply socks over the compressive stockinette until the dressing is snug. Your leg will shrink in size, so expect to add socks under the dressing. Add more 1-ply socks as needed, so your dressing fits snugly.
- General pain or pain all over your leg is expected, but pain in just one spot is not expected. If you have pain in one area, remove the dressing and look at your skin. If an area looks red or is sore, do not put the dressing back on. Do keep the compressive stockinette and socks in place and call your doctor.

Additional education may be available through the maker of your equipment.

Preparing for Prosthesis

Becoming less sensitive

To help prepare you for a prosthesis, there are some things that can help make your limb less sensitive to touch and pressure. These include:

- Tapping
- Desensitization
- Limb massage
- Scar massage

Some people find these also help lessen phantom pain. Be sure to check with your doctor or therapist before starting these techniques to prevent injury.

Tapping

Tapping should be done for 1 to 2 minutes, 3 to 4 times each day. If you find it helps phantom pain, you can do it more often.

At first, tapping can be done with your compression dressing on or off while the sutures are in place.

- Use the soft, padded parts of your fingers, not your finger nails.
- Gently tap with the pads of your fingers, over the suture line.

After the suture line is healed, you can increase the pressure. You can go from tapping to gently slapping the scar site.

- Use your fingers from one or both hands and tap or gently slap the end of your limb.

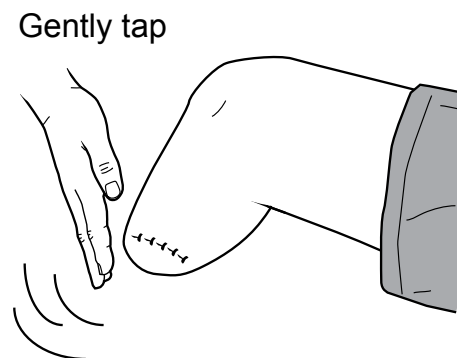

Desensitization

Do this for 2 to 3 minutes, 2 times each day, with your compression dressing off. You will start with soft cotton and move to more rough materials.

- Hold a cotton ball in your hand and gently rub the cotton ball on the skin of your limb.
- Move the cotton ball in circles and rub your entire limb.

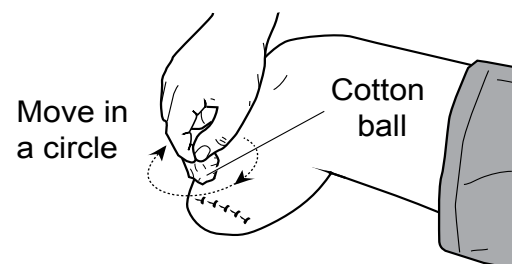

- When you are able, use a rougher material, like a paper towel, instead of the cotton ball.
- As you are able, use a terry cloth towel or wash cloth, instead of the paper towel.
- Keep doing this until you are able to tolerate the gentle rubbing of the terry cloth.

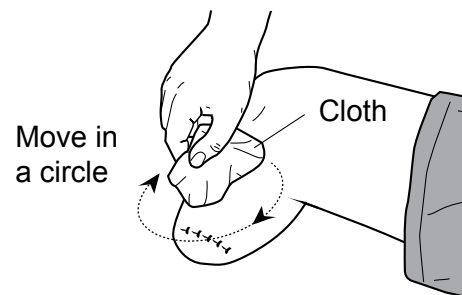

Limb massage

Massage for at least 5 minutes, 3 to 4 times each day. You can do it more often if it helps ease phantom pain. You can do massage with your compression dressing off or on.

- Using one or both hands, gently squeeze and release to massage your limb. At first, be cautious around your suture line or scar.
- Start at your suture line and massage up and around your entire limb.
- After your sutures are removed and the site has healed, you can increase the pressure when you squeeze to massage the deeper muscles.

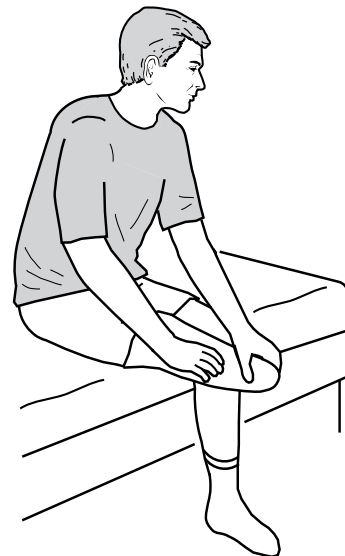

Scar massage

Scar massage is done to keep your scar from getting stiff and tight. If the scar attaches to the tissue, it can cause more pain and be a site for blisters when you wear the prosthesis. Massaging the area will help keep the scar loose and less thick.

Do this 1 time each day when you bathe.

- Before your suture line heals, you will not be pressing on the scar line. You will move the skin around the bone at the end of your limb. It is best to do this when your compression dressing is off.
 - Place 2 of your fingertips on the skin over the bony end of your limb.
 - Press firmly and move your fingers in circles across the bone.
 - Keep making circles until you have massaged all of the skin around the end of your limb.
- After your suture line has healed, place your fingers on the scar line and move in circles across your scar. Press in gently along the scar to move the skin over the tissue lying underneath.

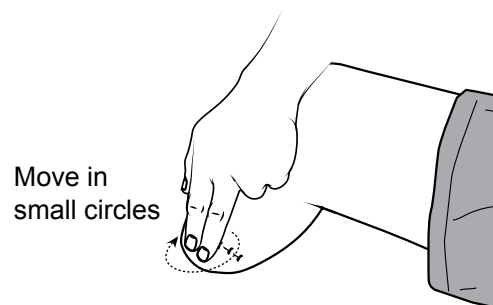

About Pain and Pain Control

It is important to control your pain as a part of your overall treatment. Uncontrolled pain can interfere with sleep, healing, thinking, activity, and appetite. Ask for relief from pain **before** your pain worsens.

Pain rating scale

How do you experience pain? Pain is personal and different for each person. We will ask you to use a pain rating scale to help us understand your pain and to set goals for pain control. You will be asked about your pain often. **Anytime you have pain, tell your healthcare team.**

Use the scale and choose the number (0 to 10), description, or face that best matches the pain you feel now.

Defense and Veterans Pain Rating Scale

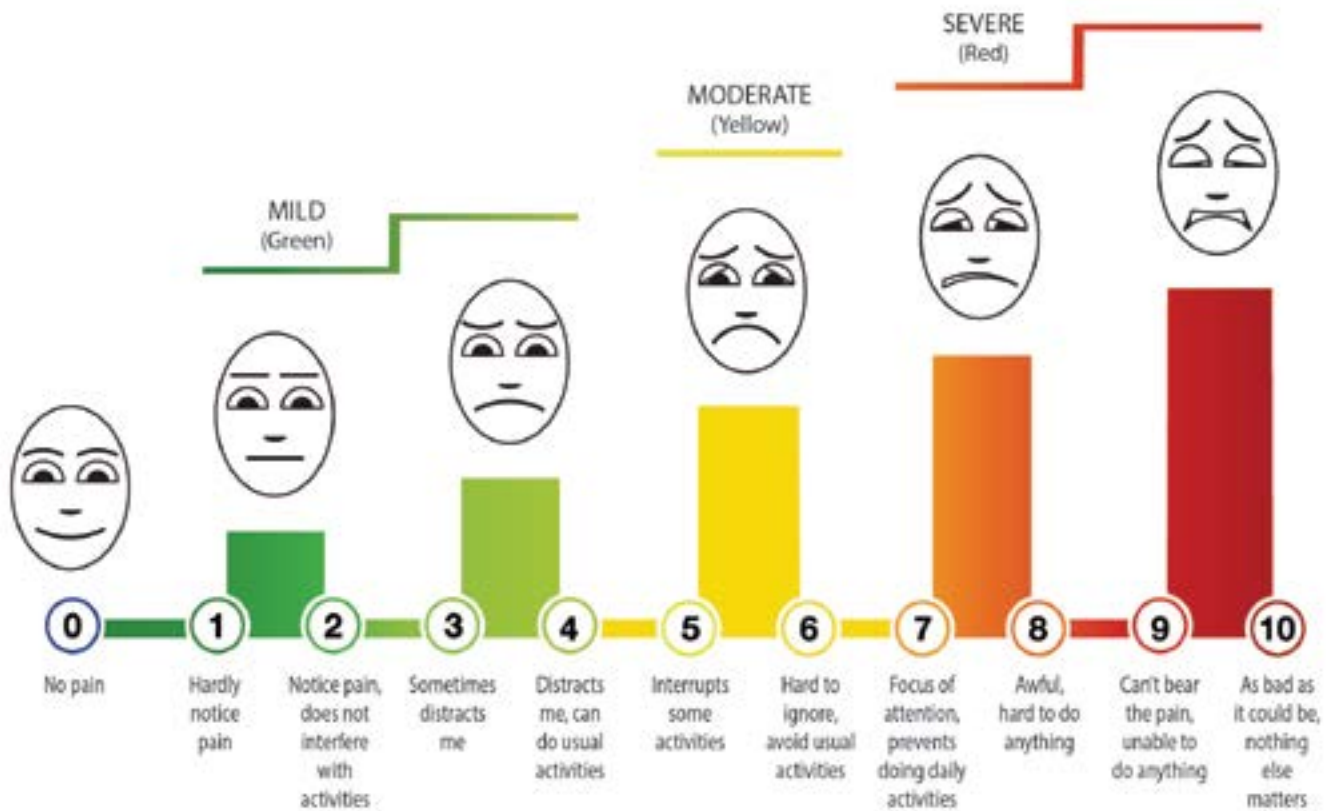

Defense & Veterans Center for Integrative Pain Management v2.0

Talking about your pain

Tell your healthcare team as much as you can about your pain. Share with them:

- **Location:** Where does it hurt?
- **Intensity:** How strong does the pain feel?
- **Duration:** How long do you feel the pain? How often does the pain occur?
- **Causes:** What makes the pain worse?
- **Relief:** What helps the pain?
- **What the pain is like:** Is it burning? Sharp? Dull? Stabbing? Spasms? Aching?

Pain control with medicine

Your doctor has ordered medicine to help control your pain. Taking your pain medicine as ordered by your doctor will bring you the most relief as your body heals. You may need to take your pain medicine before certain treatments and activities to improve your recovery.

To lower the risk of problems with your pain medicine, your doctor will treat your pain with the lowest dose of medicine for the shortest amount of time possible. When the cause of your pain goes away or lessens, your doctor may change your medicines or how you take them.

Pain control without medicine

Many patients find that using non-drug therapy for pain control brings them additional relief. Options include:

- Breathing patterns
- Massage
- Relaxation
- Visual imagery or meditation
- Exercise or movement
- Distraction, such as reading, watching a movie, or gaming
- Aromatherapy
- Heat or cold therapy (limit time of use)
- Listening to music

Talk to a staff member to learn more.



Phantom Pain

The word phantom means something that you can feel, but cannot see. After your leg is amputated, it is common to sometimes feel like your leg is still there. This is called a **phantom sensation**. If you feel pain as though your leg is still there, it is called **phantom pain**.

Cause of pain

The cause of phantom pain is not known, but experts recognize that these are real sensations, which come from the spinal cord and brain. It is believed that the parts of the brain and spinal cord that had been getting messages from that limb are now disconnected. Without input, the brain may be getting mixed signals that something is not right and interprets it as pain.

Not everyone with a leg amputation has phantom pain. When they do have it, the pain is very real, such as cramping, burning, stabbing, or shooting pain.

Some things that can make phantom pain worse:

- Being too tired
- Too much pressure on the residual limb
- Changes in the weather
- An artificial limb or prosthesis that does not fit properly
- Poor circulation
- Swelling
- Infection
- Stress

Things you can do that may help ease the pain

These feelings may get weaker and happen less often over time, but they may never go away completely. There are some things you can try to help ease the pain.

- Use massage, tapping, and squeezing to desensitize your residual limb.
- Slowly tighten and release the muscle in the limb.
- Take medicine if your doctor orders it.
- Keep the residual limb warm.
- Exercise your residual limb.
- Change your position.
- Take a warm bath or use a shower massage, but only after the incision line is closed and healed.
- Think about relaxing the part of the body that is missing.
- If you have a prosthesis on, take it off for a few minutes.
- If you do not have your prosthesis on, put it on and get active.
- If there is swelling, try an Ace wrap or shrinker sock on the limb.

If you find that your prosthesis causes more pain, you may need to adjust the socks to improve the fit or have other adjustments made. Talk to your doctor or therapist about your pain causes.

Other treatments

Most people with an amputation find the pain happens less often and is less severe over time. In some cases, other treatments may be needed to control the pain.

Treatments may include:

- **Mirror Therapy:** A mirror is used to show a reflection of your unaffected leg in place of your residual leg to trick your brain into thinking the leg is there and moving without pain. You find more about this on the next page.
- **Nerve stimulator,** called transcutaneous electrical nerve stimulation or TENS: A low-voltage electrical current is used to stimulate the nerves.
- **Biofeedback:** By using sensors, you learn to control your body's reaction to pain, such as relaxing certain muscles or slowing your breathing.
- **Acupuncture:** A technique in which practitioners stimulate specific points on the body, most often by inserting thin needles through the skin.
- **Hypnosis:** A technique in which clinicians make suggestions to a patient who has undergone a process designed to relax them and focus the mind.
- **Medicine**
- **Surgery**

Speak with your healthcare team about the options available and what may be right for you.

Phantom pain record

You may find it helpful to keep a log of any phantom pain and sensations you feel. You can make up your own record to keep track – whatever works best for you. Keep track of when you had the pain, where it felt like it was, how long it lasted, how much it hurt, and what you were doing when it happened. This might help you find some of the things that cause your pain. You may also want to keep track of what you did to ease the pain and how well it worked.

Sample Record:

Date	Pain level (0 to 10 scale)	Location and type	How often or how long	What I was doing
July 26	6 /10	Bottom of foot - burning	10 to 15 times - OR - 2 hours of the day	Waking up from nap
July 27	4 /10	Bottom of foot - achy	5 to 10 times - OR - 1 hour of the day	Sitting, watching TV

Mirror Therapy

How it works

Phantom limb pain is a painful sensation that a person may feel after a body part no longer exists. Mirror therapy can be used to help reduce these unwanted or painful phantom sensations.

The treatment uses a mirror to show a reflection of the unaffected leg in place of the residual limb. It is believed that this treatment may help retrain and calm the areas in the brain responsible for feeling pain, which are still there after an amputation. The idea is that the reflection tricks the brain into thinking that the limb is there and moving without pain. These exercises can be done for any level of amputation, as long as the opposite limb is still intact.

Setting up

Mirror

- You can use any long mirror. The size of a standard, light-weight closet mirror works well. You can buy these at a low cost from many department stores.

Position

- This can be done sitting or lying down. See the positions shown on the right.
- Place the mirror between your legs, with your residual limb behind the mirror and your unaffected leg in front.
- Anything you do with your unaffected leg should look as if you are doing it with both legs.

Getting started

- Do movements with your unaffected leg below the level of your injury.
 - For below knee amputation, focus on doing ankle movements in all directions.
- Aim to spend 15 minutes every day.
- Focus on the mirror for the entire time.
- You may feel very emotional at first, so begin slowly.



Recommended: Sitting or lying in bed with the mirror facing your unaffected leg.



Alternative: Sitting in a chair, with the mirror facing your unaffected leg.

Positioning and Stretches

Use proper positions and do stretching every day to help prevent problems. Proper positioning and stretching is important to keep a good range of motion. It is also needed if you plan to use a prosthesis.

Positions

Sitting

- Change the position of your hip and knee often.
- **Do not** sit in a chair for long periods of time with your knee bent. Use a board to keep your leg up instead.

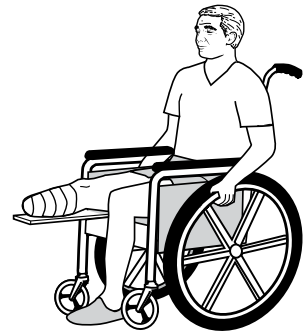

Lying Down

- Do not place a pillow under your hips, knee, or between your thighs.
- Do not put your residual limb on a pillow unless otherwise told to do so by your therapist.
- Do not hang your residual limb over the side of the bed.



❑ Prone Lying

- Lie on your stomach for 20 minutes, 2 or 3 times a day. Do not put a pillow under your stomach.
- If you are not able to lie on your stomach, you can lie on your back, unless you have been told not to by your therapist.

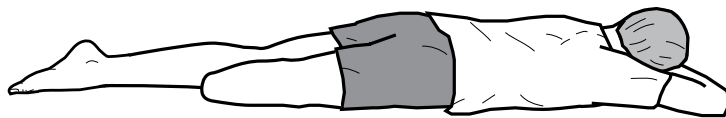

Stretches

Only do the stretches checked by your therapist.

Do each marked stretch _____ times each (repetitions) _____ times per day (sets).

Do not bounce back and forth when doing stretches.

❑ Alternative (Advanced) Prone Stretch

- Lie on your stomach. Place a rolled towel under your residual limb.
- Lie in this position for 20 minutes.
- As you stretch your hip flexor muscle, you may increase the size of the towel roll.

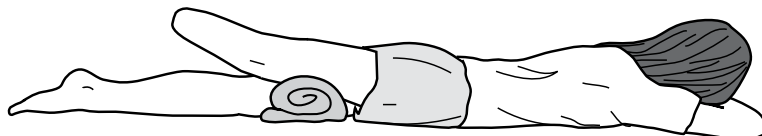

❑ Hamstring Stretch with Unaffected Leg – Lying

- Lying on your back, gently pull your unaffected thigh toward your chest with both arms.
- Slowly straighten your knee until you feel a pull behind your knee.
- Allow your knee to bend and then repeat.

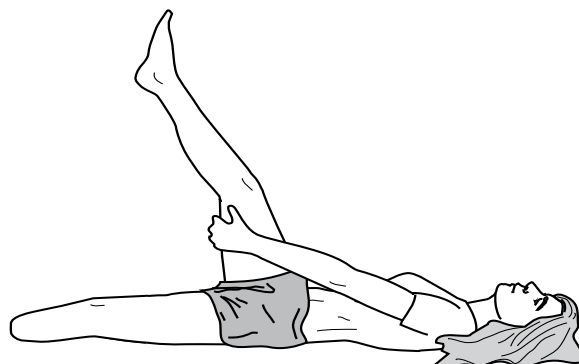

❑ Hamstring Stretch with Unaffected Leg – Sitting

- Sit with your back straight and your unaffected leg out straight in front of you.
- Reach your hand down toward your foot and lean forward to feel a stretch in the back of your upper leg.

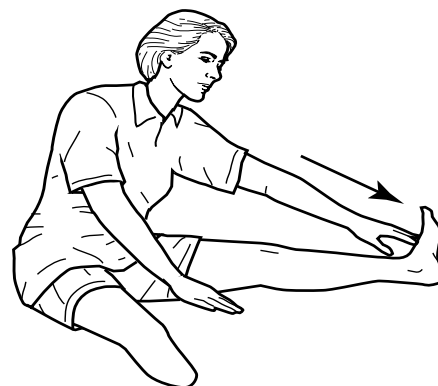

❑ Shoulder Push Up

- Lying on your stomach, place a small towel under the front of your residual limb.
- Place your elbows under your shoulders, lifting your upper body from the bed while keeping your abdomen on the table.
- You should feel a gentle stretch in your abdomen, affected hip and slight pressure in your lower back.

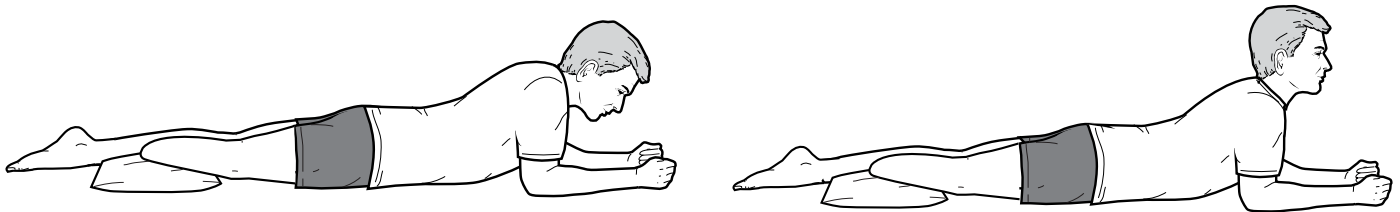

❑ Calf Stretch with Unaffected Leg

- Sit with your back straight and your unaffected leg out straight in front of you.
- Loop a towel around your foot just below your toes. You may want to use a towel or small pillow under your heel.
- Hold the ends of the towel in your hands, while keeping your knee straight. Pull back on the towel, so you feel a stretch in the back of your lower leg.

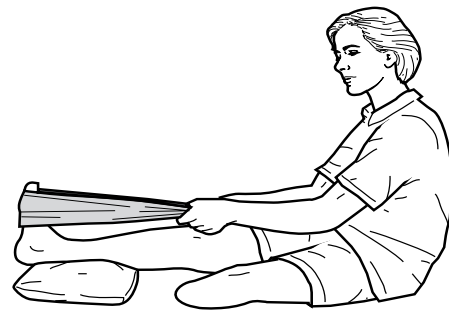

❑ Assisted Hip Flexor Stretch

- Lie on your back.
 - Bring your unaffected leg up to your chest and hold it with your arms.
 - Have someone push your amputated limb down to the bed and hold it as you count to 30 seconds.
 - Relax and repeat.
-
- When your residual limb can easily lie on the bed, scoot to the side and dangle your amputated limb over the side of the bed.
 - Repeat the above exercise.

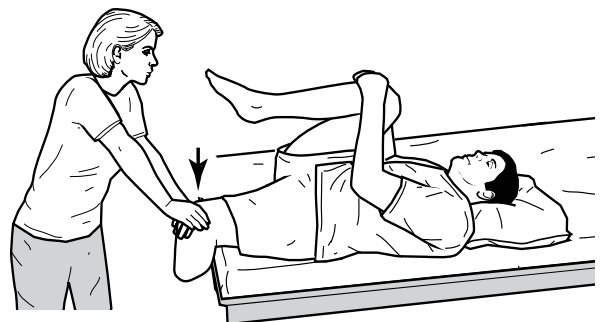
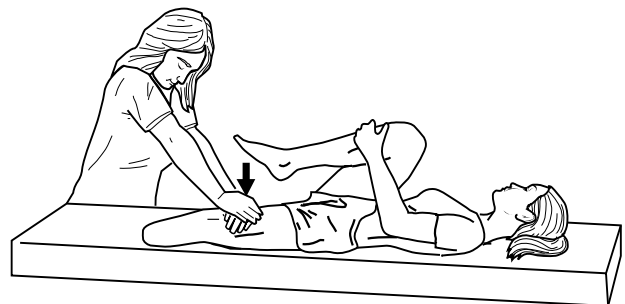

Strengthening Exercises

Do the exercises slowly with smooth motions to avoid injury. Be sure to keep breathing while you exercise. Do not hold your breath because it could cause your blood pressure to rise.

Only do the exercises checked by your therapist.

Do each marked exercise ____ times each (repetitions) ____ times per day (sets).

Quad Sets

- Lie on your back.
- Push the back of your knee down to tighten your thigh muscle.
- Hold for 5 seconds and release.
- Do this exercise with your unaffected leg and then with your residual limb.

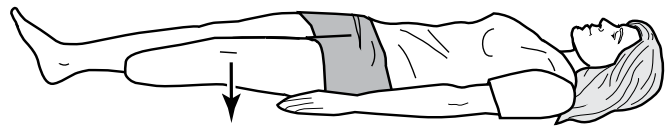

Gluteal Sets

- Lie on your back.
- Squeeze your buttocks together.
- Hold for 5 seconds and release.

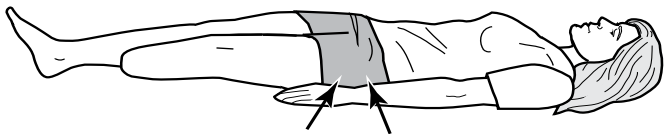

Hip Adduction With Towel Roll

- Lie on your back. Place a rolled towel or pillow between your legs as low as feels comfortable.
- Squeeze the towel between your legs while you count to 5.
- Relax and repeat.



❑ Pelvic Tilt

- Lie on your back. Bend your knee, so the foot of your unaffected leg is resting flat on the floor.
- Place your hands in the small of your back.
- Push your lower back into your hands. Hold as you count to 5.
- Relax and repeat.

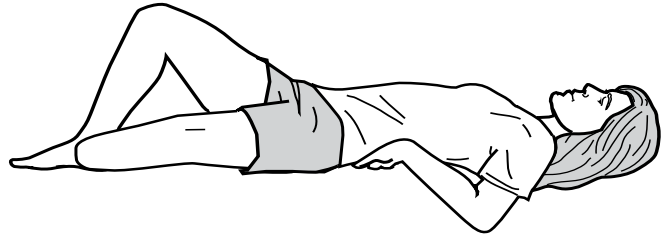

❑ Abdominal Bracing

- Lie on the floor and inhale with your lower back flat against the floor.
- Exhale and gently pull in your abdominal muscles. Keep your neck and shoulders relaxed. Do not bear down or forcefully suck in your abdomen.
- Inhale and relax.



❑ Short Arc Quads

- Place a large towel roll under the knee of your residual limb.
- Straighten your knee on your residual limb, hold for 5 seconds and release.

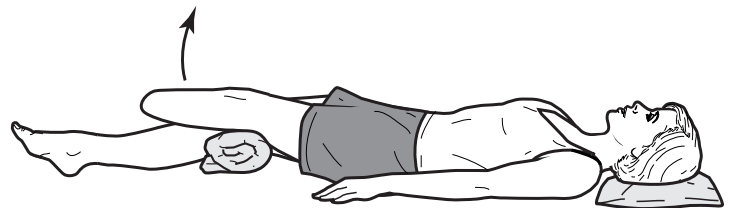

❑ Hip and Knee Bending

- Lie on your back and bend the knee of residual limb to your chest.
- Bend it as far as possible and then straighten the knee completely.
- Return to a starting position.

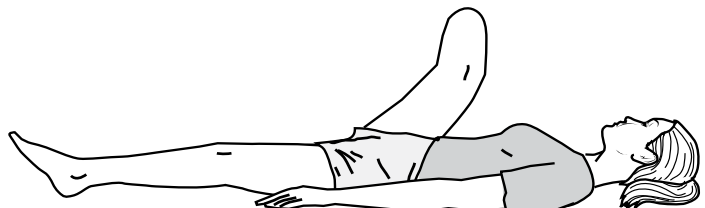

❑ Straight Leg Raise

- Bend your unaffected leg and put your foot flat on the floor.
- Lift your residual limb toward the ceiling.
- Keep your knee and residual limb straight.

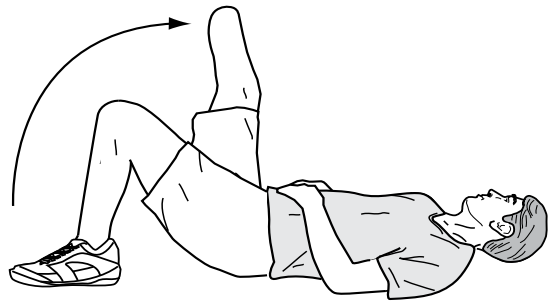

❑ Hip Outward and Inward

- Keeping the knee of your residual limb pointed to the ceiling, move your limb out to the side and then back.

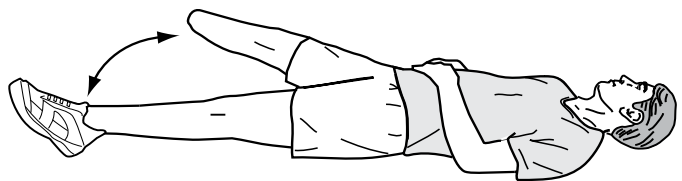

❑ Hip Abduction on Side

- Lie on your side and lift your top leg toward the ceiling. Do not turn your knee up toward the ceiling.
- Return to the starting position.
- Repeat.
- Do this same exercise with your other leg on top.

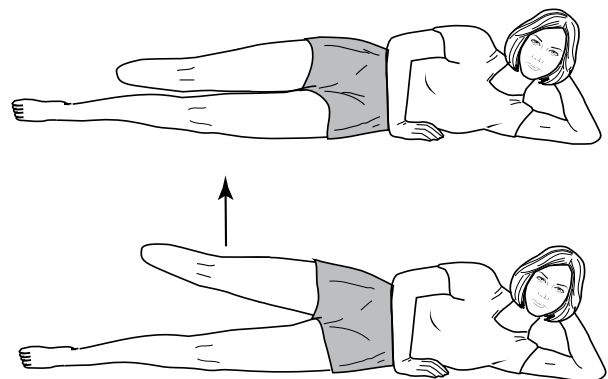

❑ Bridges

- Lie on your back with a rolled towel under the calf of your residual limb.
- Tighten the muscles in your upper leg to keep that knee straight.
- Push down into the towel and lift your buttocks up while keeping your stomach muscles tight.
- Hold for ____ seconds and then relax.
- Repeat.

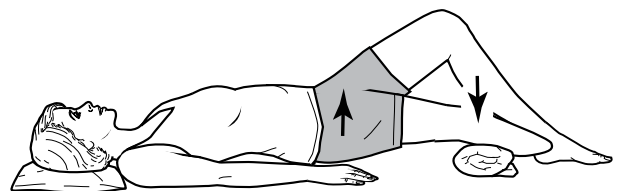

❑ Hip Extension on the Side

- Lie on your side.
- Push your residual limb straight back behind you.
- Hold and then return to the starting position.
- Repeat.

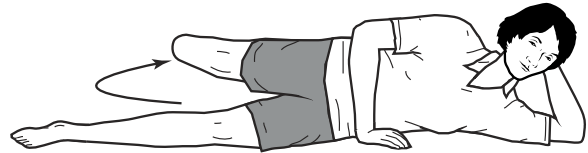

❑ Hip Extension Lying Down

- Lie on your stomach. Lift your residual limb up toward the ceiling, keeping your knee straight.
- Hold and then return to the starting position.
- Repeat.

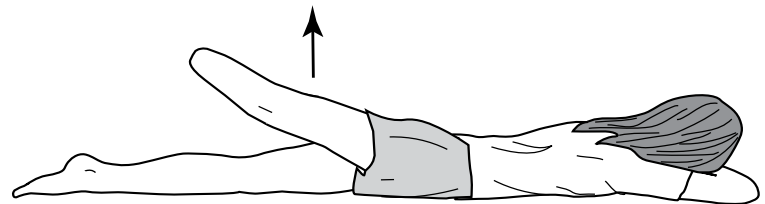
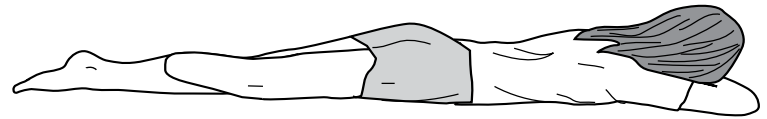

❑ Resisted Hip Abduction With Theraband

- Lie on your back and fasten a belt or theraband around your thighs as low as feels comfortable.
- Try to pull your legs apart by pushing outward against the belt or theraband.
- Push as you count to 5.
- Relax and repeat.

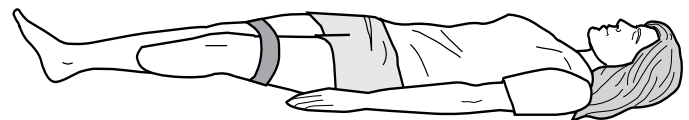

❑ Alternative Hip Adduction

- Lie on your side.
- Bring your top leg forward and let your foot rest on the floor in front of you.
- Lift your residual limb toward the ceiling.
- Return to the starting position.
- Repeat.

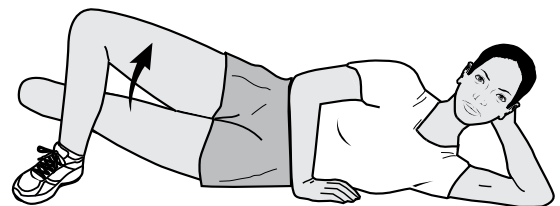

❑ Partial Sit-up

- Lie on your back.
- Bend your hips, so the foot of your unaffected leg is resting flat on the floor. Rest your hands on your thighs.
- Slowly curl up until your head and shoulder blades are off the floor.
- Look up to the ceiling as you do this exercise.
- Repeat.

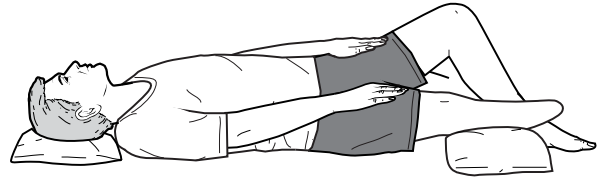

❑ Knees Up Abdominal Crunches

- Lie on your back on a pad or mat, with your knees bent, foot flat on the floor, and your arms at your sides.
- Lift your foot, head, and hands off the floor, while you tighten your stomach muscles and flatten your lower back to the floor.
- Pump your arms up and down slightly.
- Slowly return to the starting position.
- Relax and repeat.

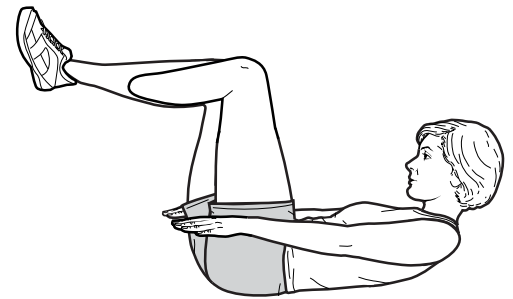

❑ Limb Lift

- Kneel down on a mat or pad to cushion your knee. Place a pillow under your foot and lower leg.
- Balance yourself on your hands and knee.
- Lift 1 arm up and hold it, then place it back down.
- Lift your residual limb up and hold it, then place it back down.
- Lift your other arm up and hold it, then place it back down.
- Lift your unaffected leg up and hold it, then place it back down.
- Repeat these moves with both legs and both arms 10 times each.

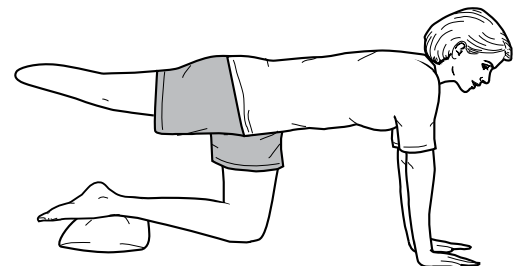
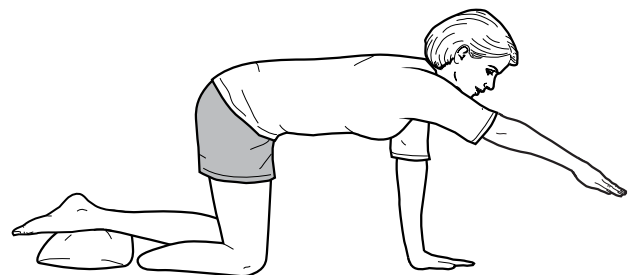

❑ Arm and Leg Lift

- Kneel down on a mat or pad to cushion your knees. Place a pillow under your foot and lower leg.
- Balance yourself on your hands and knees.
- Lift 1 arm and the opposite leg up, hold them there, then place them back down.
- Lift the other arm and opposite leg up, hold them there, then place them back down.
- Repeat these moves with both legs and both arms 10 times each.

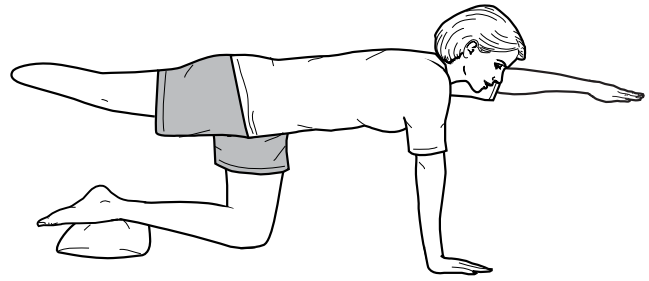

Heart Healthy Eating with DASH

DASH, or Dietary Approaches to Stop Hypertension, is an eating plan that lowers blood pressure and LDL (bad) cholesterol to reduce your risk of getting heart disease. Your healthcare provider may also recommend DASH to prevent or control other diseases and conditions, such as stroke, type 2 diabetes, and kidney stones.

Along with DASH, other lifestyle changes can help improve your health. They include staying at a healthy weight, exercising, and not smoking.

Talk to your provider for support as you make changes to your diet and lifestyle.

Follow the DASH eating plan

The food groups listed show examples of daily or weekly servings for a 2,000-calorie-a-day diet. You may need more or less servings each day based on your calorie (energy) needs. Talk to your provider for support.

Sodium - limit to 2,300 mg or less per day or the amount recommended by your provider

- 1 teaspoon of salt has about 2,300 mg of sodium.
- Most of the sodium in our diets comes from processed foods, like lunch meat, canned soups, canned vegetables, and boxed or packaged mixes.
- Read food labels to learn how much sodium is in a food.
- Use sodium-free spices or flavorings with your food instead of salt.
- Rinse canned foods to remove some of the added sodium.
- Buy foods labeled “no salt added,” “sodium-free,” “low sodium,” or “very low sodium.”



Grains - eat 6 to 8 servings per day

- 1 serving equals:
 - 1 slice of bread
 - 1 ounce of dry cereal (about ½ to 1 ¼ cups, depending on cereal type)
 - ½ cup of cooked rice, pasta, grains, or cereal
- Choose whole grains (100% whole wheat or whole grain bread, brown rice, quinoa, or oatmeal) over refined grains (white flour, degermed cornmeal, white bread, or white rice).



Vegetables - eat 4 to 5 servings per day

- 1 serving equals:
 - 1 cup raw, leafy vegetables
 - ½ cup chopped raw or cooked vegetables
 - ½ cup low-sodium vegetable juice



Fruits - eat 4 to 5 servings per day

- 1 serving equals:
 - 1 medium fruit
 - ¼ cup dried fruit
 - ½ cup fresh, frozen, or canned fruit
 - ½ cup fruit juice
- Choose whole fruits (fresh, frozen, or dried) over juice.



Fat-free or low-fat dairy - eat 2 to 3 servings per day

- 1 serving equals:
 - 1 cup fat-free or 1% low-fat milk
 - 1 ½ ounces low-fat cheese
 - 6 ounces fat-free or low-fat yogurt



Lean meats, poultry, and fish - eat 6 to 8 servings per day

- 1 serving equals:
 - 1 ounce cooked meat, fish, or poultry
 - 1 egg
- Trim away visible fat and remove skin from poultry.
- Use low-fat cooking methods, like broil, roast, poach, bake, and grill.
- Limit meat to 3 ounces at meals (about the size of the palm of your hand).
- Limit egg yolks to 4 per week.



Fats and oils - eat 2 to 3 servings per day

- 1 serving equals:
 - 1 teaspoon butter, margarine, or oil
 - 1 tablespoon mayonnaise
 - 2 tablespoons salad dressing
- Use small amounts of butter or margarine.
- Use olive oil as your first choice for oils.



Seeds, nuts, and legumes (beans, lentils, and peas) - eat 4 to 5 servings per week

- 1 serving equals:
 - ⅓ cup or 1 ½ ounces of nuts
 - 2 tablespoons nut butter
 - 2 tablespoons or ½ ounce seeds
 - ½ cup cooked beans, lentils, or peas
- Eat more vegetarian or meatless meals.



Sweets and added sugars - eat **5 or less servings per week**

- 1 serving equals:
 - 1 tablespoon of sugar, honey, maple syrup, or chocolate sauce
 - 1 tablespoon jelly or jam
 - ½ cup sorbet, sherbert, or ice cream
 - 2 small cookies
- Keep sugar on the food label to less than 10 grams per serving.
- People with male anatomy: limit sugar to no more than 150 calories or about 3 tablespoons (38 grams) per day.
- People with female anatomy: limit sugar to no more than 100 calories or about 2 tablespoons (25 grams) per day.
- A 12-ounce can of regular soda has about 40 grams of sugar!



For more information about DASH, visit:

- National Heart, Lung, and Blood Institute: nhlbi.nih.gov/health/health-topics/topics/dash
- MedlinePlus: medlineplus.gov/dashdiet.html

Tips for success

- Read food labels to learn what is in a food. This will help you to make healthier choices. Look at calories, saturated fat, sodium, and sugars.
- Use the DASH 2-day sample menu on the next page to help you get started.

Adopt healthy lifestyle habits

To boost the health benefits of eating well with DASH, practice these healthy lifestyle habits.

- **Get 7 to 8 hours of sleep a night.**
- **Maintain a healthy weight.** Talk to your doctor or dietitian about what is a healthy weight for your height.
- **Exercise regularly.** Get at least 150 minutes a week of moderate exercise, such as walking, biking, or swimming. This breaks down to just 30 minutes, 5 days a week. Start slowly, such as walking briskly for 15 minutes, twice a day.
- **Manage stress.**
- **Limit alcohol.** If you drink, do so in moderation. This means no more than 2 drinks per day for someone with male anatomy, and 1 drink per day for female anatomy.
- **Do not smoke or use tobacco products.** Visit smokefree.gov or go.osu.edu/pted3430 for tools and tips to quit.

DASH 2-day sample menu	
Day 1	Day 2
Breakfast	Breakfast
1 cup bran flakes cereal	½ cup oatmeal
1 medium banana	1 mini 100% whole wheat bagel
1 cup 1% low-fat milk	1 tablespoon peanut butter
1 slice 100% whole wheat bread	1 medium apple or 1 cup other whole fruit
1 teaspoon butter or soft margarine	1 cup 1% low-fat milk
½ cup orange juice or orange segments	
Lunch	Lunch
¾ cup chicken salad on 2 slices 100% whole wheat bread	Chicken breast sandwich with 3 ounces skinless chicken breast, 2 slices 100% whole wheat bread, 1 slice low-fat cheddar cheese, 1 large romaine leaf, 2 slices tomato, 1 tablespoon low-fat mayonnaise
Salad with ½ cup fresh cucumber slices, ½ cup tomato wedges, 1 tablespoon sunflower seeds, 1 teaspoon Italian dressing	1 cup canteloupe chunks
½ cup fruit cocktail	
Dinner	Dinner
3 ounces lean beef with 2 tablespoons fat-free beef gravy	1 cup whole grain spaghetti with ¾ cup spaghetti sauce (with no meat and less than 10 grams of sugar per serving), and 3 tablespoons Parmesan cheese
1 cup green beans sauteed in ½ teaspoon olive oil	Spinach salad with 1 cup spinach leaves, ¼ cup fresh grated carrots, ¼ cup sliced mushrooms, 1 tablespoon vinaigrette dressing
1 small baked potato topped with 1 tablespoon fat-free sour cream, 1 tablespoon low-fat shredded cheddar cheese, 1 tablespoon chopped scallions	½ cup corn, cooked from frozen
1 small whole wheat roll with 1 teaspoon tub margarine	½ cup fresh or canned pears
1 small apple	
1 cup 1% low-fat milk	
Snack	Snack
⅓ cup almonds, unsalted	⅓ cup walnuts, unsalted
¼ cup raisins	½ cup applesauce
½ cup low-fat, low-sugar Greek yogurt	1 low-fat mozzarella string cheese

Leisure as Part of Your Rehabilitation

As you learn to adapt to your amputation, talk to your healthcare team about your interests.

We will work with you to both build your skills and adjust the leisure activities you are interested in to fit your abilities.



What do you like to do?

I like to...

- do something meaningful
- be active
- feel commitment to something
- be busy
- do lots of different things
- take it easy and relax
- do something different from work and school
- be able to do what I want
- be spontaneous
- make and carry out plans
- try my own methods of doing things
- compete with others
- compete with myself to do better
- laugh and enjoy
- make use of my skills
- improve my skills
- have something to show for my efforts
- get approval for what I do
- be successful at what I do
- have a feeling of personal worth
- learn more about myself or a topic
- develop relationships with other people
- be part of a group or team
- meet new people
- develop friendships
- help others
- be in attractive surroundings
- _____

Leisure activities

Check the activities you enjoy or would like to try. Share this list with your healthcare team, family, and friends. Your community may have classes and programs available through libraries, park and recreation departments, senior centers, and fitness clubs. Activities can often be adapted to meet your needs or stage of recovery.

Relaxation activities

- | | | |
|--|---|--|
| <input type="checkbox"/> House plants | <input type="checkbox"/> Listening to music | <input type="checkbox"/> Video games |
| <input type="checkbox"/> Computer / Internet | <input type="checkbox"/> Meditating | <input type="checkbox"/> Word search games |
| <input type="checkbox"/> Crossword puzzles | <input type="checkbox"/> Movies | <input type="checkbox"/> Writing |
| <input type="checkbox"/> Jigsaw puzzles | <input type="checkbox"/> Pet care | <input type="checkbox"/> _____ |
| <input type="checkbox"/> Library | <input type="checkbox"/> Reading books | <input type="checkbox"/> _____ |

Creative activities

- Acting
- Art shows
- Baking or cooking
- Ballet
- Broadway plays
- Canning food
- Church activities
- Collectibles
- Community activities
- Concerts
- Crocheting
- Drawing
- Flower arranging
- Home repair and improvement
- Jewelry making
- Knitting
- Museums
- Needlepoint
- Opera
- Painting
- Photography
- Play musical instruments
- Pottery or ceramics
- Quilting
- Scrapbooking
- Sewing
- Singing
- Woodworking
- _____
- _____
- _____

Social activities

- Bingo
- Board games
- Card games
- Checkers or chess
- Clubs / organizations
- Cornhole / bean bag toss
- Darts
- Dominoes
- Eating out
- Going to parties
- Politics
- Pool, billiards, or snooker
- Shopping
- Socializing with friends
- Traveling
- Volunteer work
- _____
- _____

Physical activities

- Aerobics
- Badminton
- Basketball
- Bicycling or spinning
- Bocce
- Bowling
- Football
- Frisbee
- Golf
- Handball or racquetball
- Hockey
- Ice skating
- Jogging or running
- Judo or other self defense
- Shuffleboard
- Skiing
- Soccer
- Softball or baseball
- Swimming
- Table tennis
- Tennis
- Volleyball
- Walking
- Weight lifting
- Yoga
- _____
- _____
- _____
- _____
- _____



Adaptive Sports and Recreation in Central Ohio



This is a list of various adaptive sport and recreation activities in central Ohio and surrounding areas. There may be others not listed.

Adaptive and Inclusive Programming with Westerville Parks and Recreation

Serves youth and adults with developmental and physical disabilities in the Westerville and surround communities. The program provides community outings and special events for social skills, emotional well-being, continuing education, fitness and wellness, and more.

- Call: 614-901-6848
- Email: thompson@westerville.org
- Register: westerville.org/registration

Adaptive Sports Connection

Provides equipment and lessons that meet your needs from beginners to competitive athletes. Sports include cycling, kayaking, skiing and snowboarding, water skiing, climbing, paddle boarding, amputee soccer, and sailing.

- Call: 614-389-3921
- Visit: adaptivesportsconnection.org

Adaptive Sports Program of Ohio

This program supports the health and wellness of people with physical disabilities. Competitive and recreational adaptive sport programs throughout Ohio.

- Call: 330-985-0085
- Visit: adaptivesportsohio.org

City of Columbus Therapeutic Recreation Program

Sponsors recreational activities that are adapted to meet the needs of persons with disabilities. Everyone is welcome, including the people who are not disabled. Programs include wheelchair basketball, wheelchair softball, blind soccer, boccia, swimming, track and field, wheelchair football, wheelchair road racing, wheelchair rugby, and wheelchair tennis.

- Call: 614-645-5648
- Visit: columbusrecparks.com/wellness/therapeutic-recreation

City of Columbus Franklin Park Adventure Center

The Adventure Center is primarily used for our Therapeutic Recreation Program which sponsors recreational activities that are modified to meet the needs of people with disabilities.

- Call: 614-645-5648
- Visit: columbusrecparks.com/facilities/franklin-park-adventure-center

Fishing Has No Boundaries, Central Ohio

Organization opens up the great outdoors for people with disabilities through the world of fishing.

- Call: 614-383-8851
- Visit: www.fhnbcentralohio.org

Fore Hope

This organization uses golf as an instrument to help in the rehabilitation of persons with disabilities or an inactive lifestyle. The team consists of certified therapeutic recreation specialists and golf professionals.

- Call: 614-566-4242
- Visit: www.ohiohealth.com/services/neuroscience/our-programs/forehope

Greater Columbus Rowing Association and Para Adaptive Rowing Program

Para-adaptive rowing equipment, coaching, and adaptive expertise on either the ergs (indoor rowing machine) or in rowing shells (boats) are provided depending on the season.

- Email: gcraparp@gmail.com
- Visit: columbusrowing.org/para-adaptive-rowing-program

Ohio Sled Hockey

Provides the opportunity for people with physical limitations to learn about and participate in the sport of hockey. Both adult and youth teams.

- Email: OSHSledhockey@gmail.com
- Visit: ohiosledhockey.org

Paralyzed Veterans of America, Buckeye Chapter

Available sports include: wheelchair basketball, wheelchair softball, quad rugby, billiards tournaments, air rifle competition, and Columbus Marathon (wheelchair division).

- Call: 216-731-1017
- Visit: buckeyepva.org

Recreation Unlimited

This is the largest provider in the state of Ohio serving people with disabilities in the area of sports, recreation, and education.

- Call: 740-548-7006
- Visit: recreationunlimited.org
-



Shane Center for Therapeutic Horsemanship

Serves both children and adults with a wide array of disabilities. Certified instructors with North American Riding for the Handicapped Association. All horses are specially selected and trained for therapeutic riding.

- Call: 740-625-9324
- Visit: shanecenter.org

Solid Rock Therapeutic Riding Center

This is a riding center for children and adults with special needs.

- Call: 330-990-1777
- Email: solidrocknb@gmail.com

Team River Runner

Provides veterans and their families an opportunity to find health, healing, community purpose, and new challenges through adventure and adaptive paddle sports.

- Visit: teamriverrunner.org
- Email: info@teamriverrunner.org

The Miracle League of Central Ohio

This program welcomes people with disabilities from age 3 to 21 years old to play in Miracle league baseball. The field is fully accessible to all who are visually impaired, wheelchair or walker-restricted, or who use any type of mobility device.

- Email: ohiomiracleleague@gmail.com
- Visit: miracleleaguecentraloh.org

The Ohio State University Recreational Sports

Student Life Recreational Sports encourages and supports the participation of people with disabilities in all programs and services at no additional cost.

- Visit: recsports.osu.edu/membership-access/inclusive-recreation

3 Trackers of Ohio

Community sports, recreation, and educational programs for individuals with disabilities. Available sports include: cycling, kayaking, water skiing, and snow skiing.

- Call: 440-476-9905
- Visit: 3trackers.org

Vertical Adventures

Adaptive climbing for anyone with a disability or exceptionality. Whether you've climbed before or if you are new to climbing, this is for you. Join us to experience the joys, benefits, and challenges of rock climbing with our amazing staff and volunteers.

- Visit: 5.life/va/adaptive-ascents
- Call: 614-888-8393

Willow Ridge Therapeutic Riding Facility

This program provides equine assisted therapy to youth who are developmentally disabled or emotionally at risk.

- Call: 614-778-9122
- Visit: willowridgeequinetherapy.org

Saving Energy and Making Work Easier

General tips

- Wait 30 minutes after eating before doing a task. Work done after a meal causes more demand for oxygen to your heart.
- Avoid doing activities in hot and humid or very cold temperatures. Extreme heat or cold can be dangerous for the heart.
- Talk with staff about how to adapt your home to make things easier. Ask about area resources to help with the cost.



Pace yourself to save energy

- Get at least 6 to 8 hours of sleep each night.
- Rest for 20 to 30 minutes at least twice a day. Stop and rest for 15 minutes if you get tired, whether or not you have finished your task.
- Alternate easy tasks with hard tasks or spread a task out over the day.
- Focus your energy on the things you can do.
- Ask for help when things get too demanding or hire help when you can.
- Avoid stress as much as possible.

Use labor-saving methods and devices to save energy

- **Create work areas where you can comfortably sit to do things**, such as making food or grooming yourself.
- **Organize work areas and keep items where you use them.** Store things you use most often at chest height to avoid stretching to reach them.
- **Get rid of unneeded work**, such as wearing clothes that do not need to be ironed.
- **Use automatic or electric appliances**, such as an electric can opener, mixer, washer and dryer, and dishwasher.
- **Use wheels to move things.** Use a cart for your garbage cans you can pull with a riding mower. Use a cart to move your laundry.
- **Use proper body mechanics.** Slide rather than lift things. Do not lean forward without supporting yourself. Instead, rest your elbows on counter tops.
- **Use aids for daily tasks**, such as using a long-handled shoe horn or a sock aid. You can also use a grabber to reach things from a seated position.
- **Bathroom changes** can help make bathing easier, such as using a hand held shower head. Use a shower bench to sit and an elevated toilet seat.

Phases of Recovery from Amputation

According to the Amputee Coalition, there are six phases that describe the recovery process of a new amputee. While not everyone goes through the recovery process the same way, understanding these phases can help you to know that your feelings are normal and part of the healing process. Family, friends, and caregivers can also better support you on your journey.

About each phase

Phase	Characteristic	Description
Enduring	Surviving surgery and pain	Hanging on; focusing on right now to get through the pain; blocking out feelings of distress about the future.
Suffering	Questioning: Why me? How will I...?	Intense feelings about loss, fear, denial, anger, and depression; feeling vulnerable and confused; may go back to enduring phase.
Reckoning	Becoming aware of the new reality	Coming to terms with the loss; accepting what is left; thinking about how the future will change.
Reconciling	Putting the loss in perspective	Getting control back; becoming aware of own strengths and uniqueness; being more assertive; managing own illness and recovery; changing body image; feeling a need for intimacy.
Normalizing	Reordering priorities	Balancing life; setting new routines; doing things that matter again; setting priorities that are not focused on the loss; advocating for self.
Thriving	Living life to the fullest	Being more than before; trusting self and others; feeling confident; being a role model to others. Not everyone reaches this level.

Adapted with permission from the Amputee Coalition, www.amputee-coalition.org.

Depression After Amputation

As you or a loved one learns to deal with the changes in your life, you may have feelings of sadness, anxiety, frustration, or anger. When sadness changes into depression, it is important to seek help. Talk to your doctor or others on your healthcare team.

Signs of depression

When a person is depressed, they have several signs nearly everyday that last at least 2 weeks, such as:

- Increased frustration, irritability, or grouchiness
- Loss of interest and pleasure in activities you used to enjoy
- Feeling sad, empty, or down
- Crying more than usual
- Feeling slowed down, restless, or unable to sit still
- Feeling worthless or guilty
- Feeling pessimistic or hopeless
- Feeling anxious or worried
- Changes in appetite
- Weight loss or gain
- Change in sleep patterns – being unable to sleep or sleeping too much
- Problems concentrating, thinking, remembering, or making decisions
- Withdrawing from people or events you normally enjoy
- Loss of energy or feeling tired all the time
- Sexual problems

If you have any of these signs for more than 2 weeks, or if you have had thoughts of suicide or of trying to harm yourself or others, **see your doctor or get help right away.**



Prevention

- Learn about amputation and recovery. Information can help lessen your fears. Talk to your healthcare team about your questions and concerns.
- Talk to someone who has been there. Ohio State's Peer Visiting Program information is on page 64 and 65.
- Make the most of rehabilitation and keep track of your progress. The more you recover, the better you will feel.
- Spend time with family and friends. Talk about your feelings.
- Keep up your interests and hobbies, or start new ones.
- Stay active.
- Do not drink alcohol.
- Talk to a healthcare professional as soon as you notice signs of depression.

Where to get help

- **In the hospital**, talk with your nurse, doctor, psychologist, social worker, or therapist. They can provide or recommend help for you.
- **After discharge**, talk to your primary care doctor or social worker.
- **Ohio State’s Rehabilitation Psychology** program provides help to patients coping with chronic illness, chronic pain or disability. To make an appointment or get a referral, call 614-293-3830. They can give you information about available mental health services.
- **Counselors** – Your doctor, nurse, social worker, or hospital chaplain can provide counseling or help you find a counselor if you need one. Individual counseling, group therapy, or family counseling may be helpful.
- **Church, temple, mosque, or other place of worship** – These can be sources of fellowship and community. Many people find it helpful to talk with a spiritual leader about their grief.
- **Social work organizations** – Social work organizations and local hospitals can help you find services and support groups in your area.
- **Mental health services** – Mental health organizations and centers may provide education and information about other available services.
 - Contact Mental Health America of Franklin County at 614-221-1441 or visit mhafc.org for a resource directory and fact sheets.
 - Contact National Mental Health America at 800-969-6642 or visit mhanational.org for health information and help finding treatment and support groups.
- **Community Resources** – Lutheran Social Services offers 24-hour referrals to community resources. Call 211 or visit lssnetworkofhope.org/211centralohio.
- **In an emergency**, call 911 or go to or call the Emergency Department at University Hospital at 614-293-8333.

Help Anytime

If you have feelings of hurting yourself or others, get help right away. There are 24-hour hotlines that you can call anytime.

- **National Suicide Prevention Lifeline** – 1-800-273-TALK (8255)
- **NetCare Access** (24-hour mental health and substance abuse intervention) – 614-276-2273
- **Suicide Prevention** – 614-221-5445

Adapting to Life

Learning to adapt after having an amputation can be hard. It is common to have fear, stress, sadness, and frustration. Don't try to go through it alone. Talk about your feelings with people you feel close to and trust.



Tips to help you adapt

- **Be kind to yourself.** Pay attention to your health. Get plenty of rest and eat a balanced diet. Do not use alcohol and other substances because they can add to your problems.
- **Take one day at a time.** Do the best you can to get through each day. Have a schedule and aim to do one important task each day.
- **Learn about your abilities and care.** Understanding the changes in your abilities and how to take care of yourself can lessen stress and prevent problems. Educate others to help them to support you and to lessen their fears.
- **Get the equipment you need.** Talk to your healthcare team about what equipment you need, where to get it, and what resources there are to help you with this.
- **Set goals.** Start by listing some simple activities you want to do, like writing letters or talking to friends. Later you can list future plans. Remember goals and plans can be changed.
- **Write in a journal.** Write down your feelings of loss. Write down things you are thankful for. You can also use your journal to track your progress.
- **Do relaxation techniques.** Relaxation techniques can help you to let go of the physical and emotional stress that change can cause in your life.
- **Use leisure activities to find pleasure.** Your therapist will work with you to find activities you enjoy and help you learn new skills.
- **Connect with others who have been through it.** Your healthcare team can connect you to individuals or support groups. There are also communities of people who connect online to share experiences and support.
- **Be active.** Being active can boost hormones that lower stress and create a sense of well-being. Work with your therapist on how you can safely be active.

Relaxation Techniques

Learn relaxation techniques to reduce stress and anxiety. Try different ones to find what works best for you. Practice them often and your ability to relax will improve over time. Here are some options to try.

Listening to music

Listen to music that helps you to feel calm and relaxed, such as spa music, classical music, or nature sounds. Try also guided meditation music.

Breathing exercises

1. Find a quiet room.
2. Turn on music that you find relaxing.
3. Get into a relaxing position.
4. Close your eyes and think of an image in your mind that will help you to relax, such as a calm, peaceful setting or a place you have enjoyed visiting.
5. Breathe in deeply. Hold your breath and tense your muscles. Keep them tense for a second or two.
6. Relax your muscles as you breathe out.
7. Starting with the muscles in your lower legs, work your way up your body to your head, tightening and relaxing each muscle group.

Guided imagery

Close your eyes and think of a time and place when you felt safe and comfortable. Imagine those surroundings, sights, smells, and sounds. Bring as much of that experience back to the here and now as possible. When you feel ready, take a deep breath and open your eyes.



Aromatherapy

Aromatherapy is the use of essential oils from plants as therapy to improve your well-being. Some oils, such as lavender, are thought to produce a calming effect. They can be inhaled or diluted and used on skin.

Positive thinking

Thinking negative thoughts can cause stress and muscle tension. Create some positive statements to replace negative self-talk. Repeat these statements to yourself and use them to motivate you. Some examples are:

- I am doing the best that I can.
- I care about myself.
- I will try again. I can do this.

Relaxation resources

- **Guided Imagery Exercises**
go.osu.edu/guidedimagerypractices
- **Mindfulness Practices**
go.osu.edu/mindfulness
- **Heart-Centered Practices**
go.osu.edu/heartpractices
- **Relaxation Response**
go.osu.edu/relaxationresponse

Using a Walker on Curbs Without Prosthesis

Your therapist will show you how to use a walker before you have a prosthesis. These instructions are the same for above or below knee amputation.

Going up a curb

Forward Method

- Walk straight up to the curb and place all 4 legs of the walker up on the curb.
- Push straight down on the walker and step up with your unaffected leg.

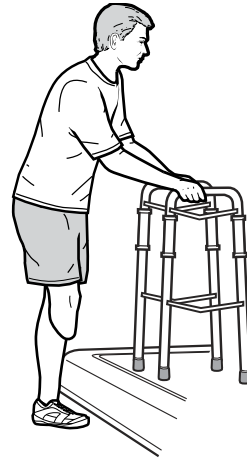

Backward Method

- Walk up to the curb and turn so your back is to the curb.
- Step up on the curb with your unaffected leg.
- Lift the walker and put all 4 legs of the walker up on the curb.
- Turn back around carefully.

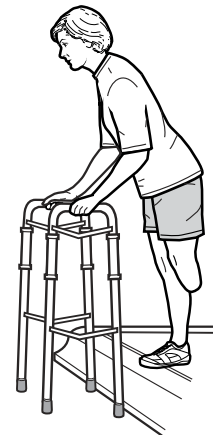
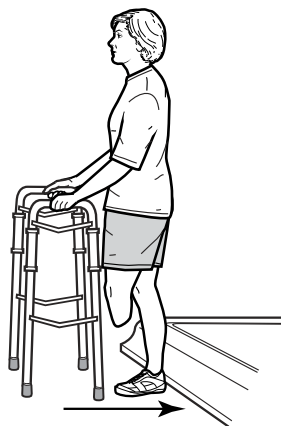

Going down a curb

- Walk up to the edge of the curb.
- Put all 4 legs of the walker on the ground below.
- Supporting your weight on the walker, step down with unaffected leg.

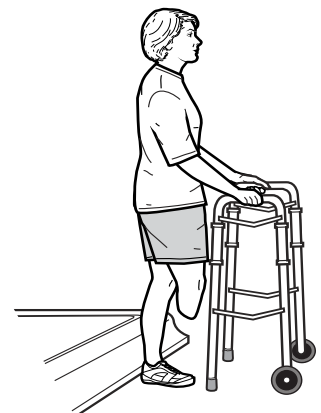
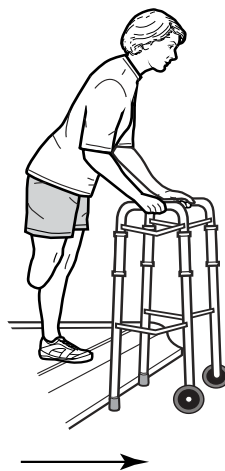

Never go down a curb backwards.

Using Crutches With Amputation

Using crutches safely

Be Sure Your Crutches Fit You

- Adjust the crutches for your height. The top of the crutch should be 1 to 2 inches below your armpit.
- Your crutch tips should be 2 to 3 inches out to the side of your feet, so you do not trip on your crutches.
- There should be a slight bend in your elbow when holding onto the crutches.
- Keep your elbows close to your sides to help keep the crutches against your chest.
- The pressure or weight goes on your hands and not on your armpits. Nerve damage can result if weight is placed on the armpits for a long period of time.

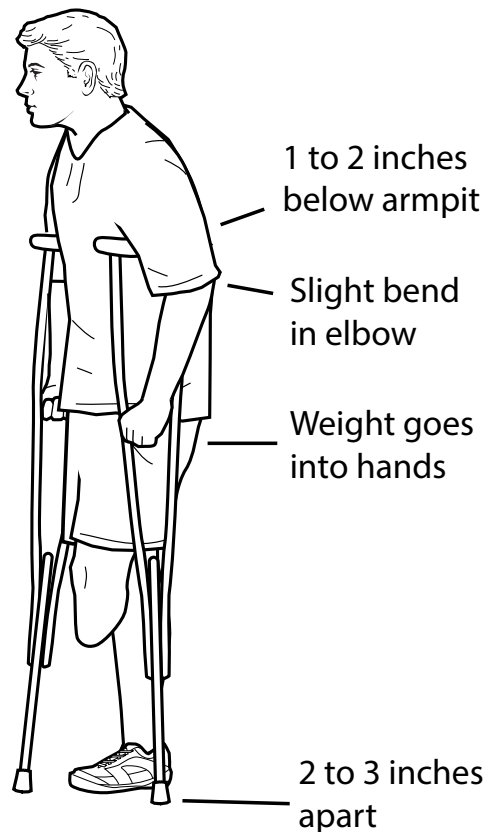

Prevent Falls

- Make sure the crutch tips, grips, and pads are in place on the crutches before using them for safety.
- Clean the crutch tips to make sure that they are free of dirt and stones.
- When walking on carpet, pick up your crutches more than when you walk on tile or linoleum floors.
- Put away all throw rugs on the floor.
- Take your time and do not try to walk too fast.
- Keep your head up and look ahead. Do not look at your feet when walking.

Weight bearing levels

You may need to limit the weight you put on your leg and prosthesis if you have one. Follow the order from your doctor or therapist. Your therapist will mark those that apply to you.

Non-Weight Bearing

Without a prosthesis, you will need to support your weight on your unaffected leg and the crutches.

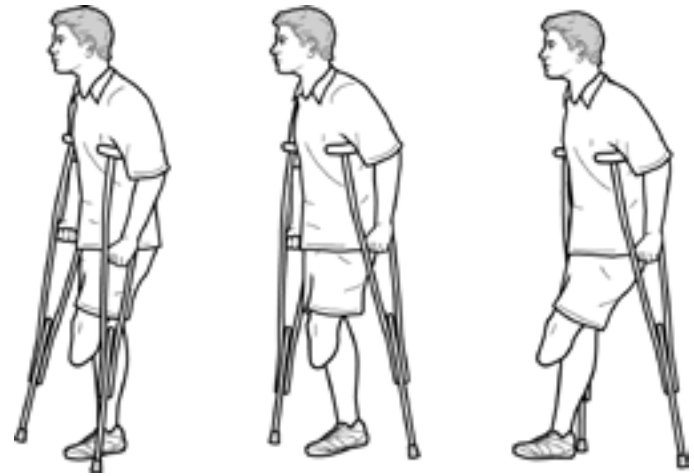

Touch Down Weight Bearing

Touch the foot of your prosthetic leg on the ground only to help your balance, but do not put weight on it.

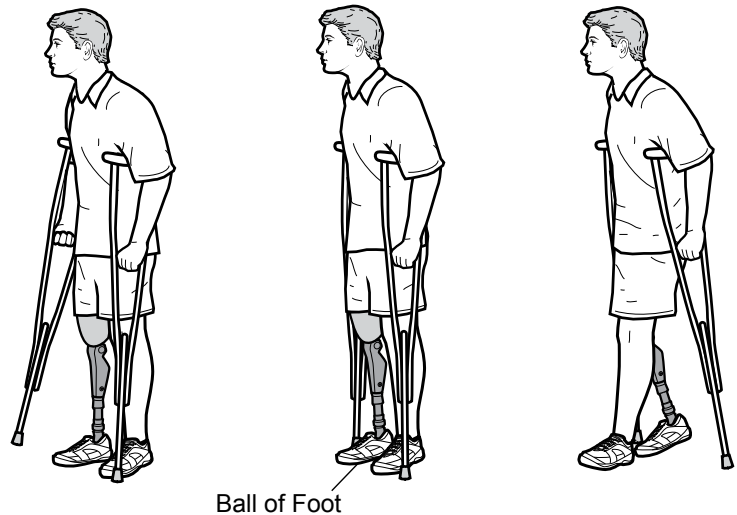

Partial Weight Bearing

Put 30% to 50% of your body weight on your prosthetic leg.

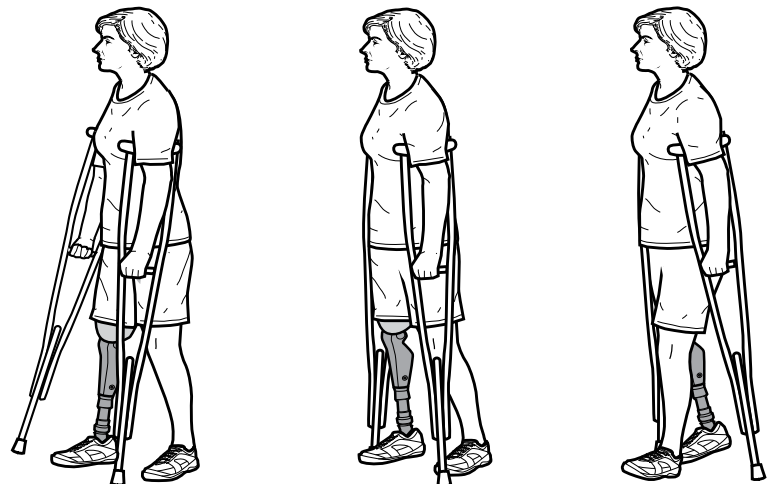

Weight Bearing as Tolerated

Put as much weight on your prosthetic leg as you can tolerate.

Standing up

- Put both crutches on the side of your residual limb.
- Lean forward and push off with your arm from the chair.
- Stand up putting your weight on your unaffected limb and crutches. Once standing, place your crutches under your arms.

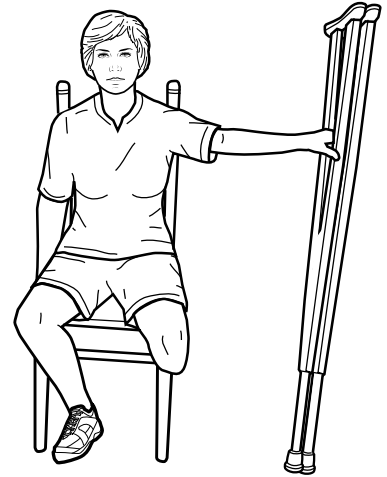

Sitting down

- Remove the crutches from under your arms and place both of them together on the side of your residual limb.
- Hold onto the crutches hand grips with one hand. Use your other hand to hold onto the arm rest or edge of the chair and slowly sit down.

Stairs

- Do not attempt to climb stairs or curbs until you have complete confidence in using your crutches. For safety reasons, you can sit down and scoot up and down the steps on your bottom if needed.
- If you have a rail, put both crutches under one arm and hold onto the rail for safety.

Getting into and out of a car

Getting Into a Car

- Have someone open the door and move the seat back as far as possible.
- Back up to the car door until you feel the edge of the seat. Grab the back rest with one hand and the hand grips of the crutches with the other.
- Tip your head to avoid bumping it. Sit down using your unaffected leg to bear your weight.
- Put the heel of your unaffected leg on the car frame and push back to move across the seat until your residual limb can be swung into the car.



Getting Out of a Car

- To get out of the car, turn in the seat to face the door. Place your foot out onto the ground. Be careful not to bump your head.
- Place one hand on the seat back and the other hand on the hand grips of the crutches.
- Stand up and support your weight on your unaffected leg and the crutches.



Taking a Wheelchair Up and Down Stairs and Curbs

Please note: If the wheelchair has anti-tippers to keep it from tipping over backwards, they will need to be removed before moving the wheelchair up and down stairs and curbs. Remember to put the anti-tippers back on the wheelchair when you are done.

Going up the stairs

2 people are needed to get the wheelchair up the stairs. Do NOT try this with 1 person. It is unsafe. The stronger of the 2 people should be behind the wheelchair. This person will do most of the lifting.

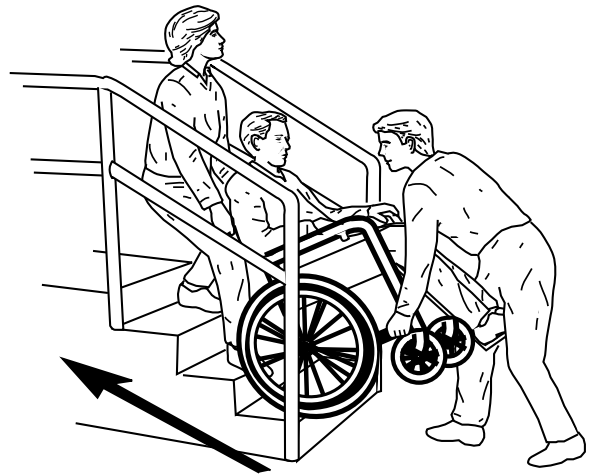

1. Back the wheelchair up to the stairs.
2. Get into position:
 - 1 helper gets on the stairs and holds the handles. **Make sure that the handle grips do not slip off.** Have 1 foot on the step above the wheelchair and the other foot on the next higher step.
 - The other helper gets in front of the wheelchair and holds onto its frame just above the front wheels. **Do NOT hold onto any parts that can come off, such as the footrests or armrests.**
 - Both helpers should bend their knees and arch their backs before lifting.
3. Together, both helpers tilt the wheelchair back, finding the balance point where only the back wheels are on the step.
4. Gently lift and roll the wheelchair up onto the next step. If the person in the wheelchair is able to help, they should pull back on the wheels.
5. The helpers should reposition themselves on each step after each lift.
6. After going up all the steps, keep the chair tilted back until the front wheels clear the top step. Gently lower the wheelchair so that all 4 wheels are on the ground.

Going down the stairs

You will need 2 people to get the wheelchair down the stairs. Do NOT try this with 1 person. It is unsafe. The stronger of the 2 people should be behind the wheelchair. This person will do most of the lifting.

1. Roll the wheelchair forward to the stairs.

2. Get into position:

- 1 helper gets in back of the wheelchair and holds onto the handles. **Make sure that the handle grips do not slip off.**
- The other helper gets on the stairs in front of the wheelchair and holds onto its frame just above the front wheels. **Do NOT hold onto any parts that can come off, such as the footrests or armrests.** Have 1 foot on the second step and 1 foot on the third step.
- Both helpers should bend their knees and arch their backs before moving the wheelchair.

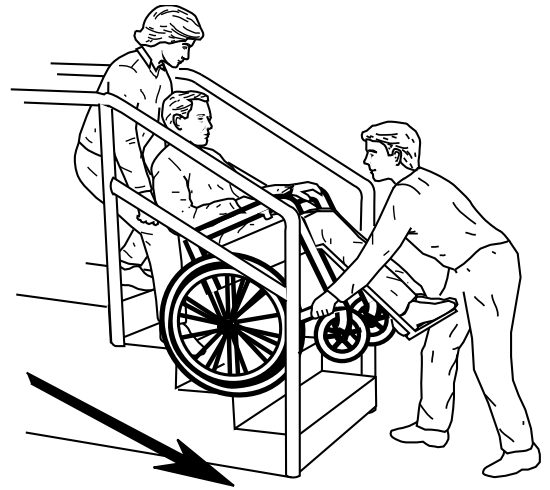

3. Together, both helpers tilt the wheelchair back

finding the balance point where only the back wheels are on the step.

4. Gently roll the wheelchair down each step.

5. The helpers should reposition themselves on each step after each lift.

6. When the chair is at the bottom of the stairs, gently lower the wheelchair so that all 4 wheels are on the ground.

Going up a curb

1. Push the front wheels of the wheelchair straight up to the curb.
2. Tip the wheelchair back and put the front wheels up on the curb.
3. Push the wheelchair forward until the back wheels are in contact with the curb.
4. Use your hip on the back of the wheelchair to push it forward and up onto the curb.

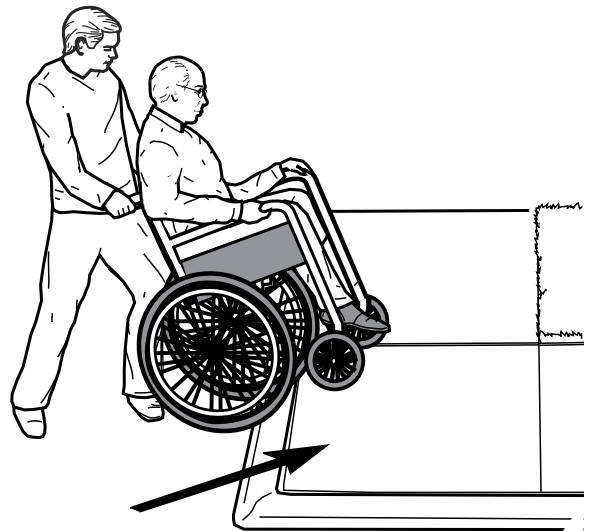

Going down a curb

1. Turn the wheelchair around facing away from the curb.
2. Step carefully off the curb.
3. Slowly roll the back wheels off the curb, blocking the back with your hip.
4. Maintain a wheelie as you back the front wheels and legs away from the curb. Once cleared, slowly lower the front wheels and turn the wheelchair around to go forward.

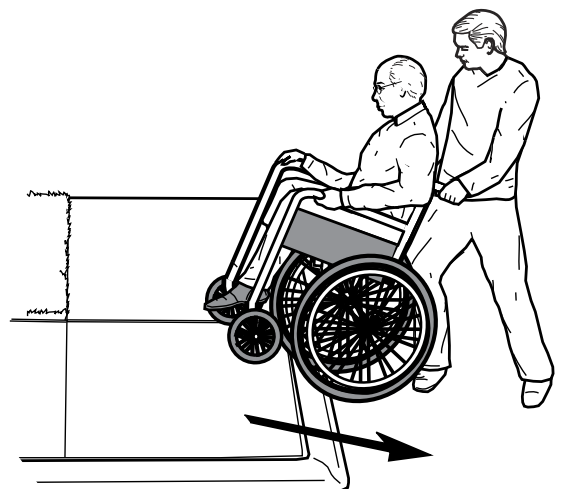

How to Adapt an Entrance for a Wheelchair

If you use a wheelchair, you may need to change the entrance of your home for easier access. You may need to have sidewalks, ramps, platforms, and lifts installed. Check with your city about the building codes, rules and regulations that may affect installation. **Building permits may be required.**

Sidewalk leading to a ramp

Sidewalks are recommended to be at least 36 inches wide to accommodate the average width of a wheelchair of 27 to 29 inches.

- **Use solid materials for the sidewalk**, such as cement, brick, or wood. They provide a smooth surface for the wheelchair to travel over and make snow removal easier in the winter.
- **Make the sidewalk slightly higher than ground level** so that water will drain.

Ramps

Plan for a ramp to be 3 to 4 feet wide. The length of the ramp depends on the total height of

your entry steps (ground to threshold rise). The standard ratio for ramps is 1:12. This means each inch above the ground (rise), you will need 12 inches or 1 foot of ramp length.

- **Ramps longer than 30 feet will need a landing for safety.** Mark the beginning and ending of each ramp section with contrasting paint or tape for safety.
- **Use solid materials for the ramp**, such as wood, cement, or metal.
- **Use a non-slip surface on the top of the ramp**, such as a “brushed” surface on cement. A commercial non-slip floor covering or safety treads may be preferred for other surfaces. Paint mixed with sand is another option to provide a non-slip texture.

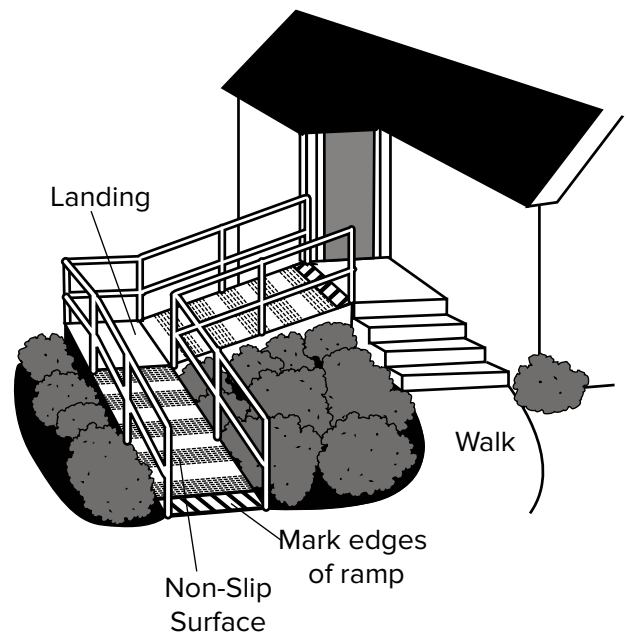
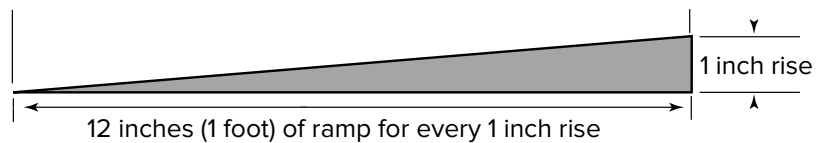

- Add lighting to make the ramp safe for night time use.
- Avoid building over stairs, to allow guests stairway entry.
- Improve curb appeal by adding shrubs and landscaping near the ramp.

Landings and platforms

An **entry platform**, level with the threshold, is required at the door. This platform needs to be a minimum of 5 feet wide by 5 feet long.

The **landing at the bottom of the ramp** should be at least as wide as the ramp and at least 5 feet long. If a turn is required at this landing, the minimal size is 5 feet wide by 5 feet long.

Level platforms are needed to break up ramps that are longer than 30 feet. If a 90 degree turn is needed, the platform must be 5 feet wide by 5 feet long. If a 180 degree turn is needed, the platform must be 5 feet wide by 8 feet long.

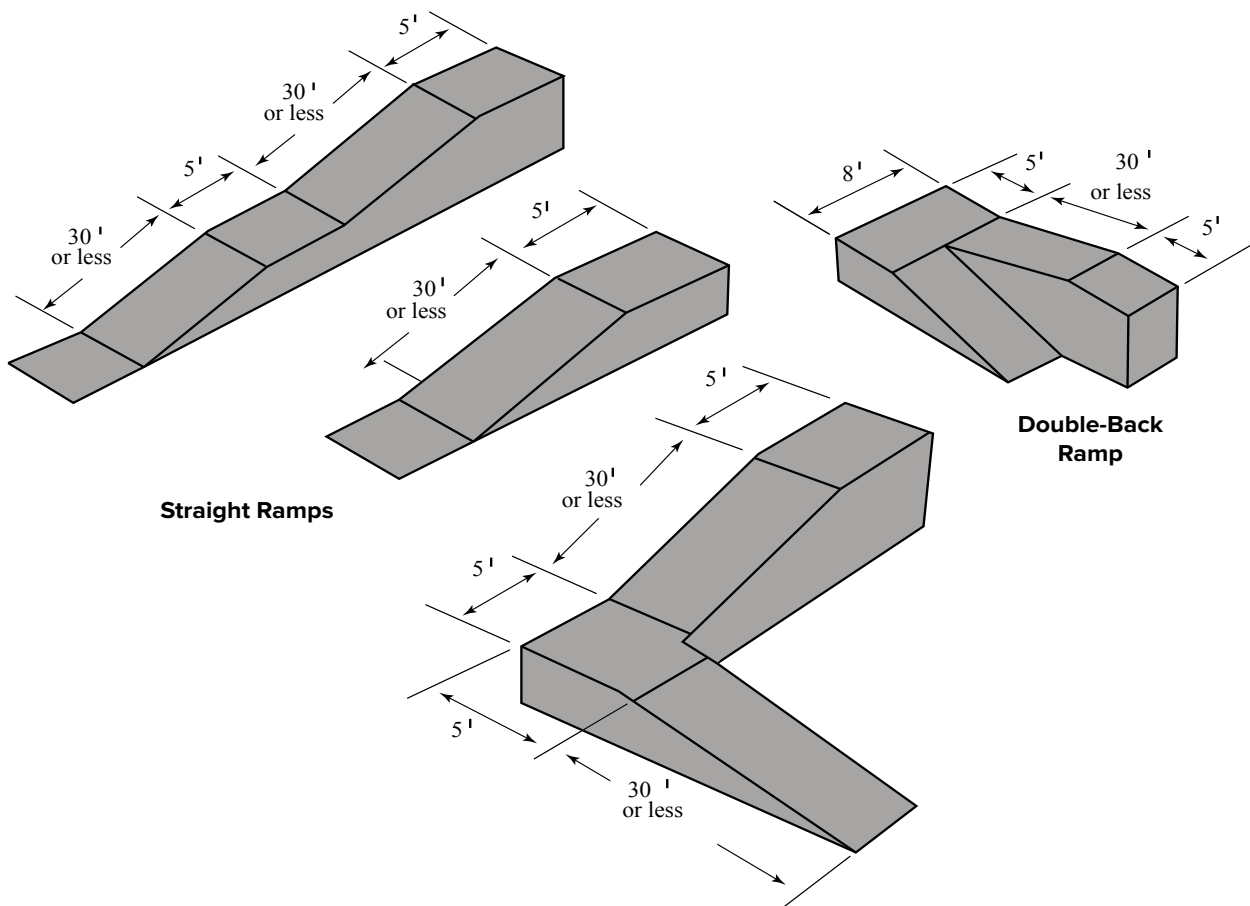

Handrails

Handrails are required if a ramp has a 6 inch rise or greater or if the ramp is longer than 6 feet (72 inches).

Handrails need to:

- Be 2 inches in diameter (wood) or at least 1½ inches in diameter (metal).
- Extend 3 inches out from the ramp support posts and walls.
- Be mounted 30 to 34 inches above the ramp surface.
- Extend 1 foot (12 inches) past the end of the ramp and end at a post/wall or be rounded off.
- Have ramp guardrail installed 36 inches above the ramp surface.
- Have a wheel guide installed, at least 2 inches high, along both sides of the ramp floor. This will prevent the front wheels of the wheelchair from slipping off the ramp edge.

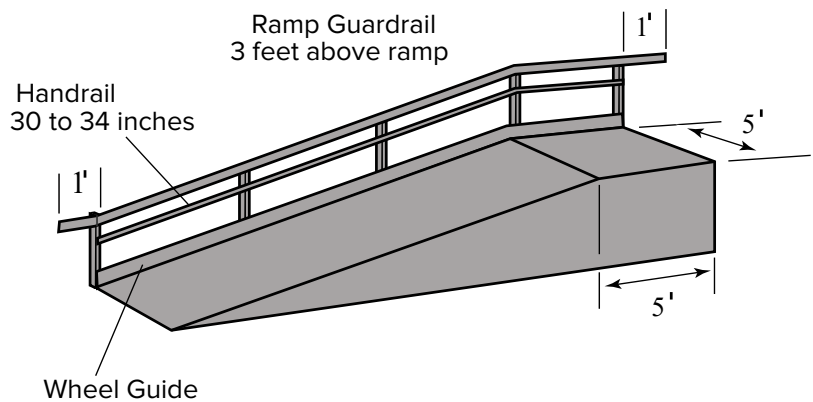

Electric porch lifts

Porch lifts can be more expensive than ramp construction. If there is not enough room for a ramp or if extensive ramping is required, a lift becomes an affordable option. Search for local suppliers online with the search term “wheelchair lifts and ramps.” The lifts are weather proof and have a lock and key for safety and security.

Lift Considerations

- **Lifts must sit on a sturdy platform of 5 feet wide by 5 feet long.** Cement, bricks, or patio blocks may be used.
- **You will need an outside electrical outlet.**
- **An outside light is needed for safety.**
- **You may need to build a platform “bridge”** from the lift (in its raised position) to the entry door. This platform should be at least 5 feet long.
- **The lift should be able to handle a load of 300 to 400 pounds.**
- Lifts can be ordered or adjusted to meet a variety of heights.

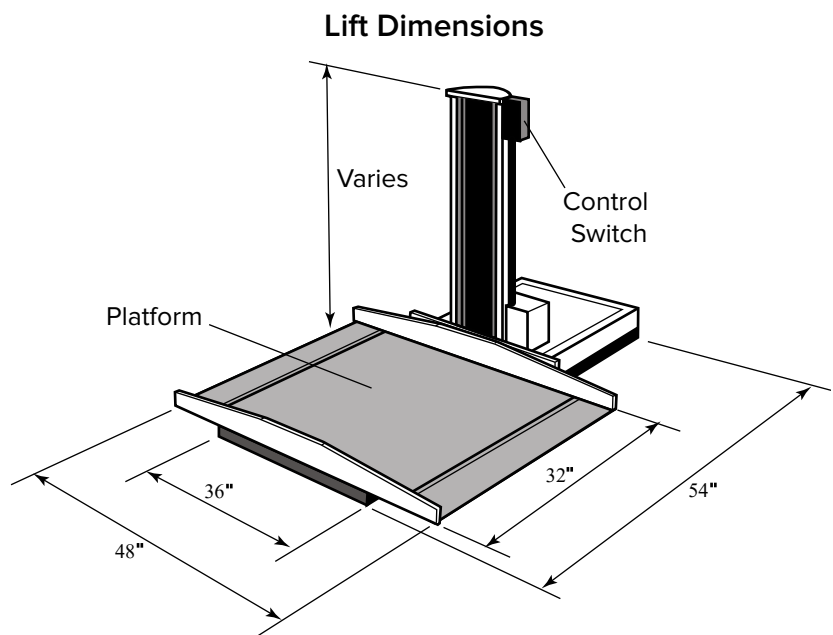

Overview of Peer Support

Benefits of Peer Support

No one is potentially in a better position to understand about living life with an amputation or supporting a person with limb loss or limb difference than someone who has been there. An experienced, well-trained peer can offer encouragement and information from a place, and at a pace, that an individual in this circumstance can better absorb.

At the heart of the Amputee Coalition's mission is our Peer Support Programs, which includes our Certified Peer Visitor (CPV) Program, National Support Group Network, and Hospital Partnership Program. Our goal is to make sure that no one goes through this journey alone. With over 1,000 Certified Peer Visitors and over 400 support groups across the country, our volunteers offer emotional support, encouragement, and vital information as individuals and family members who can relate to the limb loss and limb difference journey which can be a turning point in the recovery process.

How to Request a Peer Visit

Peer visits take place every day across the country, whether in-person or virtually. If you have had an amputation, are scheduled to have an amputation, were born with a limb difference, or are a parent, spouse or caregiver of a person with limb loss or limb difference, you may request a complimentary peer visit from an Amputee Coalition Certified Peer Visitor. Please note that our Certified Peer Visitors do not provide in-home visits. If you are requesting a peer visit for someone other than yourself, we will need to verify that the individual has consented to speak with one of our volunteers.



Online Peer Visit Request Form

<https://www.amputee-coalition.org/support-groups-peer-support/certified-peer-visitor-program/request-a-peer-visit/>

Email

peersupport@amputee-coalition.org

Call

(888) 267-5669 ext. 8124
(9:00 AM–5:00 PM ET)

Amputee Coalition Support App

Download the free Amputee Coalition Support App to request a peer visit via Apple App Store, Google Play and/or Web browser: <https://cpvapp.amputee-coalition.org>.

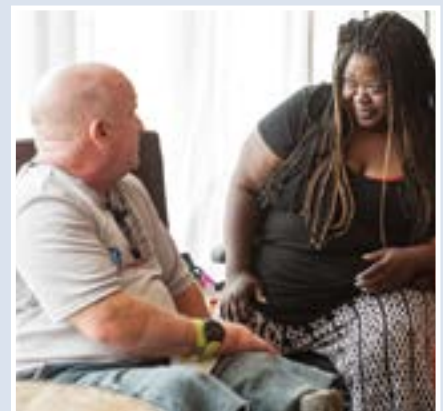

Amputee Coalition Support App

The Amputee Coalition Support App is free and was designed for those living with limb loss, limb difference and caregivers. This app embodies the power of connection and makes the support and outreach process easier for you. Available via **Apple App Store**, **Google Play** and Web browser: <https://cpvapp.amputee-coalition.org>.



Interested in becoming a Certified Peer Visitor (CPV)?

The Amputee Coalition's Certified Peer Visitors are trained volunteers who provide information and support for individuals about to undergo an amputation or who currently have limb loss and limb difference. There are three categories of peer visitors that we train:

1. A person with limb loss or limb difference, starting at age 13
2. A family member of a person with limb loss or limb difference
3. Military / VA : an individual with current or previous military or VA experience who is living with limb loss or limb difference

How can I become a CPV?

Becoming a CPV involves submitting an online CPV application, successfully completing a background check, and passing an 8-hour training course offered in-person at one of our hospital partners, in conjunction with a registered support group, or virtually. If you are interested in becoming a CPV and would like to be notified of future trainings, please email peersupport@amputee-coalition.org to be placed on our CPV Training notification list.

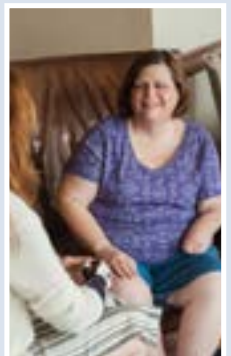
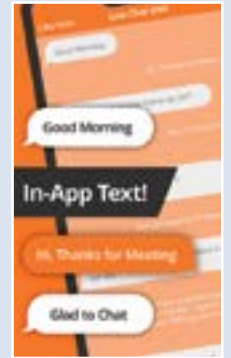

Resources and Support Groups

Resources

Amputee Rehabilitation at Ohio State Wexner Medical Center

Supports your physical and emotional needs resulting from the loss of limb due to an accident, illness, birth defect, or cancer.

wexnermedical.osu.edu/rehabilitation

Amputee Coalition

Connect with support groups, certified peer visitors, social media sites, and resource specialists or information and resources.

888-267-5669 or amputee-coalition.org

Disability Rights Ohio

Protects and advocates for the rights of people with disabilities who live in Ohio.

1-800-282-9181 or disabilityrightsohio.org

Occupational Therapy Driver Rehabilitation Program

The Ohio State University Wexner Medical Center program supports safe driving through vehicle adaptation and skills development.

614-685-5600 or wexnermedical.osu.edu/drive

Opportunities for Ohioans with Disabilities

614-438-1200 or toll-free at 1-800-282-4536, or ood.ohio.gov

Transportation Resource Guide

Lists transportation resources for Franklin County and surrounding Ohio counties.

patienteducation.osumc.edu/Documents/trans-resources.pdf

Support groups

Amputee Coalition – Support Group Listing

amputee-coalition.org/support-groups-peer-support

Ohio State Using Your Prosthesis: Below Knee Amputation Book

Learn about preparing for and using your prosthesis, including stretching, exercises, and resources.

go.osu.edu/pted5361



Prosthetic and Orthotic Companies

Below is a sample list of companies in Columbus and central Ohio that provide prosthetics and special braces, called orthotics. Go to their websites for other locations. There may be other companies in your area. Go to www.abcop.org to find an accredited facility or search for more locations at www.yellowpages.com. Be sure to check with your insurance company to see if they have a certain company you should use.

Ace Prosthetics, Inc.

aceprosthetics.com

4971 Arlington Centre Blvd., Suite A
Columbus, OH 43220
614-291-8325

American Orthopedics

amerortho.com

Columbus Office:
1151 W. 5th Ave.
Columbus, OH 43212
614-291-6454

Lima Office:
855 W. Market St., Suite C
Lima, OH 45805
419-909-0404

Marion Office:
Marion Centre Mall
1459 Marion-Waldo Road, #230
Marion, OH 43302
740-375-9100

Boston Orthotics and Prosthetics

bostonoandp.com

566 E. Main St., Columbus, OH 43215
614-231-4256

Capital Prosthetic & Orthotic Center, Inc.

capitalprosthetics.net

4678 Larwell Drive
Columbus, OH 43220
614-451-0446 or 1-800-215-0764

Hanger Prosthetics & Orthotics, Inc.

hangerclinic.com or 877-442-6437

Locations in Columbus:

1357 Dublin Rd.
Columbus, OH 43215
614-481-8338

1210 Gemini Place, Suite 101
Columbus, OH 43240
614-436-3516

255 Taylor Station Road, Suite 200
Columbus, OH 43123
614-471-8210

515 E. Main St., Suite 100,
Columbus, OH 43215
614-992-6440

Next Step Prosthetics

nextstepohio.com

4830 Knightsbridge Blvd., Suite M
Columbus, OH 43214
614-305-5155

Optimus Prosthetics

optimusprosthetics.com

975 Bethel Road, Columbus, OH 43214
614-263-5462

Prosthetix Shop

prosthetixshop.com

431 Ohio Pike, #124 South
Cincinnati, OH 45255
513-843-5126 or 859-440-3178



THE OHIO STATE UNIVERSITY

WEXNER MEDICAL CENTER

wexnermedical.osu.edu